



ES1000



**ZERO EMISSION
URBAN JOBSITE**

↙ GROUPE MECALAC
KEY FIGURES

5000

MACHINES/YEAR

1000

EMPLOYEES

270M€

TURNOVER

5%

TURNOVER
INVESTMENT
ON R&D

GROUP MECALAC LOCATIONS

-  FACTORIES
-  SALES COMPANIES

MECALACBAUMASCHINEN
MECALAC CONSTRUCTION EQUIPMENT UK LTD
MECALAC TURKEY



R&D, STEELWORK ASSEMBLY AND SALES OF MECALAC
ROAD ASSEMBLY AND SALES OF MECALAC SITE
IMPLEMENTATION AND SALES OF MECALAC EXCAVATORS
DUMPERS AND COMPACTORS OF MECALAC EXCAVATORS
LOADERS
MANUFACTURING OF HYDRAULIC COMPONENTS AND
WELDING STATION



↘ DISTRIBUTION

86 COUNTRIES
220 DEALERS



BREAKDOWN OF TURNOVER

30%
FRANCE

20%
GERMANY
AUSTRIA

15%
GREAT BRITAIN

35%
OTHER EXPORT

➔ A GLOBAL OFFER

➔ RANGE

ZERO EMISSION



EXCAVATORS

WHEEL EXCAVATOR - DADDO



WHEEL EXCAVATORS



CRAWLER SKID-EXCAVATORS



CRAWLER EXCAVATORS



RAIL-ROAD EXCAVATORS



LOADERS

COMPACT WHEEL LOADERS



WHEEL LOADERS



SWING LOADERS



TELESCOPIC LOADERS



SWING TELESCOPIC LOADERS

BACKHOE LOADERS

BACKHOE LOADERS - CENTER MOUNT



BACKHOE LOADERS - SIDESHIFT



DUMPERS

SITE DUMPERS TA



SITE DUMPERS MIX



DUMPER REVOTRUCK



COMPACTION ROLLERS

SINGLE DRUM ROLLER



TANDUM VIBRATORY ROLLERS



↳ CUSTOMERS' ACTIVITIES





MECALAC BAUMASCHINEN

R&D, steel work, assembly and sales of MECALAC wheel loaders



INNOVATION AND DESIGN OUR GUIDELINE

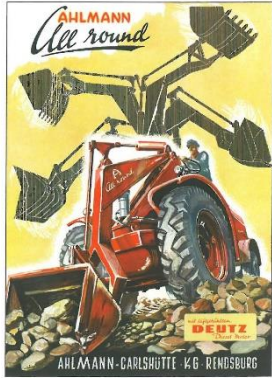

1953
1ST AHLMANN SWING LOADER



1992
1ST 4-WHEEL STEERING SWING
LOADER



2020
1ST SWING LOADER OF A NEW ERA

MCL2



MCL4
MCL4+
Short Boom



MCL6
MCL6+
Short Boom



MCL8



WHEEL LOADERS

AX700



AX850



AX1000



AF1050



AF1200



TELESCOPIC LOADERS



SWING TELESCOPIC LOADER



↘ SWING LOADERS



AS600



AS750



AS850



AS1000



AS1600



AS210

SWING LOADERS



STABILITY



MOBILITY



SPACE MANAGEMENT



100 %



100 %

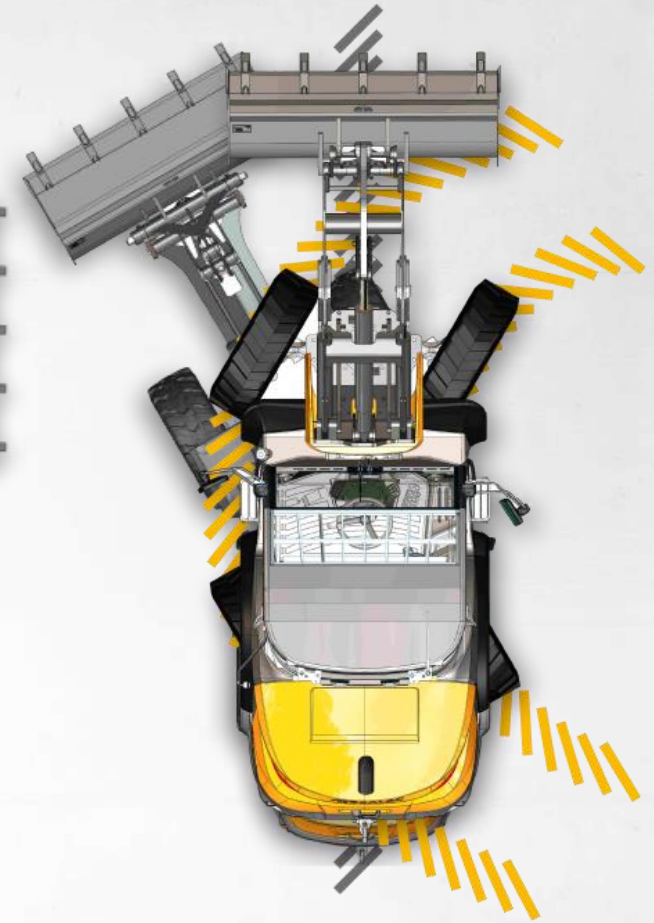

100 %



Switch to
**SPACE
MANAGEMENT**





INHALT



ENTWICKLUNG BAGGER E12

INSTALLATION / ENTWICKLUNG ES1000



Atmospheric carbon dioxide amounts and annual emissions (1750-2021)

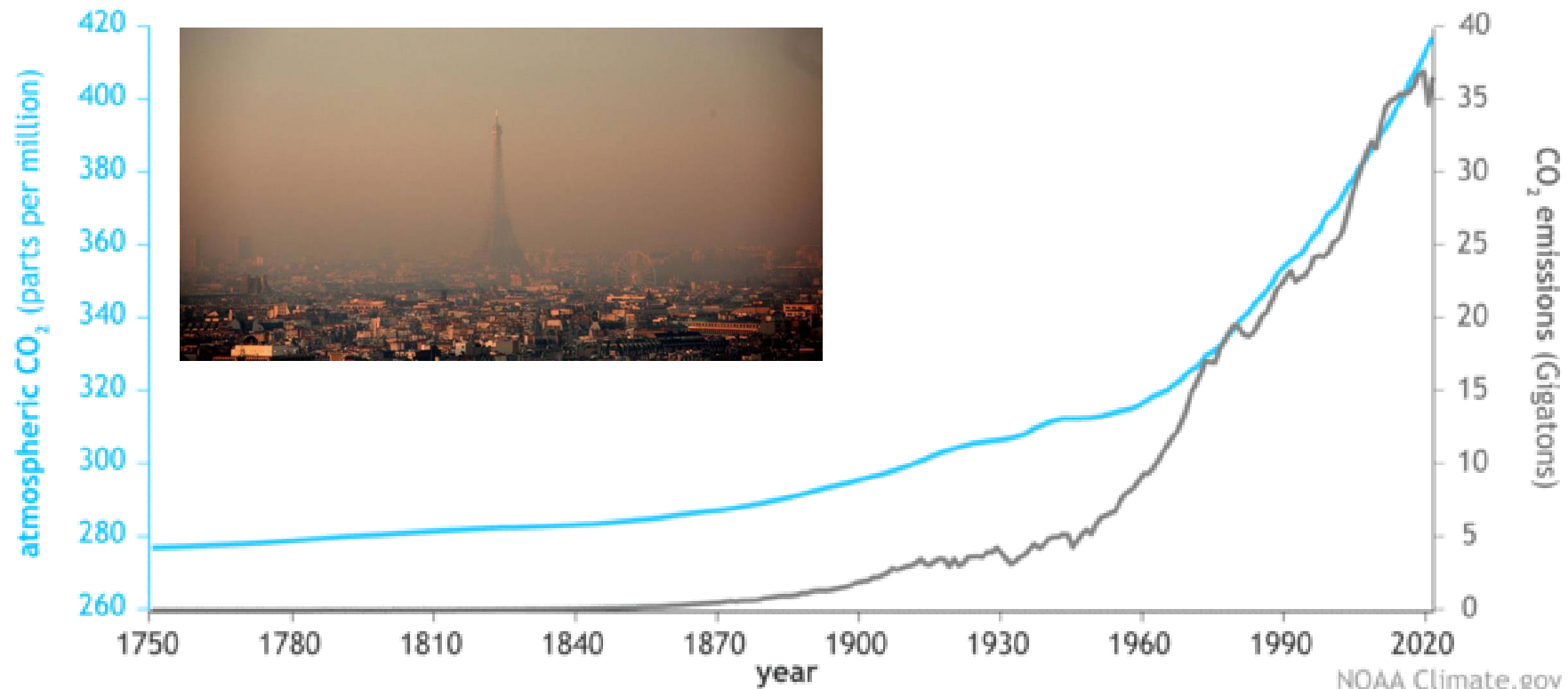

NOAA Climate.gov
Data: NOAA, ETHZ, Our World in Data

Grenzwerte von 2002 bis jetzt

Stickoxide und Partikel stark reduziert, CO₂ aber nicht



Emissionsgesetzgebung für Mobile Maschinen: EU Stufe V – Fact Sheet

3. Einführungsdaten und Grenzwerte [g/kWh] für Motorenkategorie NRE (CI/SI), Vergleich zu vorherigen Stufen nach 97/68/EG

Leistung [kW]		2003	2004	2005	2006	2007	2008	2009	2010	2011	2012	2013	2014	2015	2016	2017	2018	2019	2020	2021	2022		
0 < P < 8	Typgenehmigung																	Stufe V CO 8,00 / HC+NOx 7,50 / PM 0,40 ³⁾ / PN -					
	Inverkehrbringung ¹⁾²⁾																	Stufe V					
8 ≤ P < 19	Typgenehmigung																	Stufe V CO 6,60 / HC+NOx 7,50 / PM 0,40 / PN -					
	Inverkehrbringung ¹⁾²⁾																	Stufe v					
18 ≤ P < 37 19 ≤ P < 37 ⁴⁾	Typgenehmigung	Stufe II CO 5,5 / HC 1,5 / NOx 8,0 / PM 0,8			Stufe III A CO 5,5 / HC+NOx 7,5 / PM 0,6													Stufe V CO 5,00 / HC+NOx 4,70 / PM 0,015 / PN 1x10 ¹² [#kWh]					
	Inverkehrbringung ¹⁾²⁾	Stufe II			Stufe III A													Stufe V					
37 ≤ P < 56	Typgenehmigung	Stufe II CO 5,0 / HC 1,3 / NOx 7,0 / PM 0,4			Stufe III A CO 5,0 / HC+NOx 4,7 / PM 0,4			Stufe III B CO 5,0 / HC+NOx 4,7 / PM 0,025									Stufe V CO 5,00 / HC+NOx 4,70 / PM 0,015 / PN 1x10 ¹² [#kWh]						
	Inverkehrbringung ¹⁾²⁾	Stufe I		Stufe II		Stufe III A			Stufe III B									Stufe V					
56 ≤ P < 75	Typgenehmigung	Stufe II CO 5,0 / HC 1,3 / NOx 7,0 / PM 0,4			Stufe III A CO 5,0 / HC+NOx 4,7 / PM 0,4			Stufe III B CO 5,0 / HC 0,19 / NOx 3,3 / PM 0,025		Stufe IV (01.10.2013) CO 5,0 / HC 0,19 / NOx 0,4 / PM 0,025									Stufe V CO 5,00 / HC 0,19 / NOx 0,40 / PM 0,015 / PN 1x10 ¹² [#kWh]				
	Inverkehrbringung ¹⁾²⁾	Stufe I		Stufe II		Stufe III A			Stufe III B		Stufe IV (01.10.2014)									Stufe V			
75 ≤ P < 130	Typgenehmigung	Stufe II CO 5,0 / HC 1,0 / NOx 6,0 / PM 0,3			Stufe III A CO 5,0 / HC+NOx 4,0 / PM 0,3			Stufe III B CO 5,0 / HC 0,19 / NOx 3,3 / PM 0,025		Stufe IV (01.10.2013) CO 5,0 / HC 0,19 / NOx 0,4 / PM 0,025									Stufe V CO 5,00 / HC 0,19 / NOx 0,40 / PM 0,015 / PN 1x10 ¹² [#kWh]				
	Inverkehrbringung ¹⁾²⁾ ; NRMM	Stufe II			Stufe III A			Stufe III B		Stufe IV (01.10.2014)									Stufe V				
	Inverkehrbringung ¹⁾²⁾ ; Traktoren	Stufe I		Stufe II		Stufe III A			Stufe III B		Stufe IV (01.10.2014)									Stufe V			
130 ≤ P < 560	Typgenehmigung NRMM	Stufe II CO 3,5 / HC 1,0 / NOx 6,0 / PM 0,2			Stufe III A (2005-07-01) CO 3,5 / HC+NOx 4,0 / PM 0,2			Stufe III B CO 3,5 / HC 0,19 / NOx 2,0 / PM 0,025		Stufe IV CO 3,5 / HC 0,19 / NOx 0,4 / PM 0,025									Stufe V CO 3,50 / HC 0,19 / NOx 0,40 / PM 0,015 / PN 1x10 ¹² [#kWh]				
	Typgenehmigung Traktoren	Stufe II			Stufe III A			Stufe III B		Stufe IV									Stufe V				
	Inverkehrbringung ¹⁾²⁾	Stufe II			Stufe III A			Stufe III B		Stufe IV									Stufe V				
P > 560	Typgenehmigung																	Stufe V CO 3,50 / HC 0,19 / NOx 3,50 / PM 0,045 / PN -					
	Inverkehrbringung ¹⁾²⁾																	Stufe V					
		2003	2004	2005	2006	2007	2008	2009	2010	2011	2012	2013	2014	2015	2016	2017	2018	2019	2020	2021	2022		

¹⁾ Für Motoren der Stufe I und II, deren Herstellungsdatum vor den genannten Daten der Inverkehrbringung liegt, können die Mitgliedsstaaten den Zeitpunkt der Erfüllung der genannten Anforderungen um 2 Jahre verschieben. Ab Stufe IIIA wurde diese Regelung verpflichtend, für Stufe V hat sie keine Gültigkeit.

²⁾ Bis Stufe IV: Inverkehrbringung des Motors, ab Stufe V: Inverkehrbringung von Motor und Maschine

Motorraum AS1600 Stage V

3,6 l

100 kW@2200 rpm



- + AdBlue Tank
- + Pumpe
- + Heizung
- + Leitungen



La Jamais contente - 1899

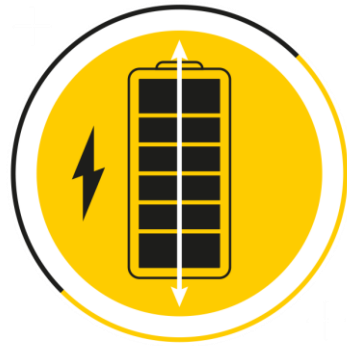

Autonomia

THE MEDIUM SIZE, THE PERFECT SCALE FOR URBAN JOBSITES

DIGGING



11-ton Excavator

 **ZERO
EMISSION
URBAN
JOBSITE**



1000-liter Swing loader

LOADING



6-ton Site-dumper

TRANSPORTING

Mecalac



- Probleme auf Baustellen

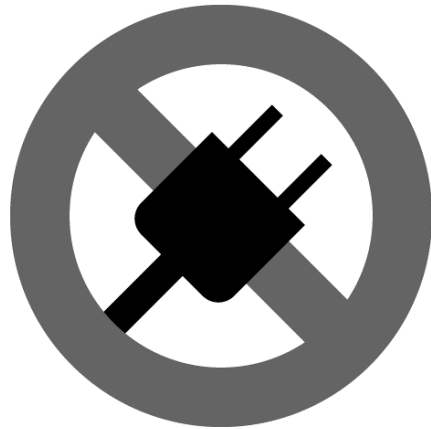

Baustelle nicht an
das Stromnetz
angeschlossen



Nicht genügend
Leistung auf der
Baustelle

MECALAC ZERO EMISSION ECOSYSTEM



E12

**ZERO EMISSION
URBAN JOBSITE**



ES1000



ED6

MECALAC

e12
AUTONOMY
PERFORMANCE
COMPACTNESS:



DIGGING

+



+

LOADING



-

HANDLING

+



HANDLING TOOL CARRIER

CUSTOMER BENEFITS

Switch to AUTONOMY

BATTERIES ARCHITECTURE



LESS MEANS MORE

150 kW.h

8h

e12



A NEW DIRECTION FOR URBAN JOBSITES

CUSTOMER BENEFITS

Switch to PERFORMANCE

MOTORS ARCHITECTURE

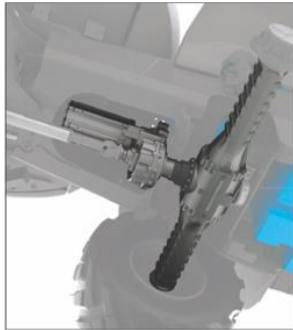
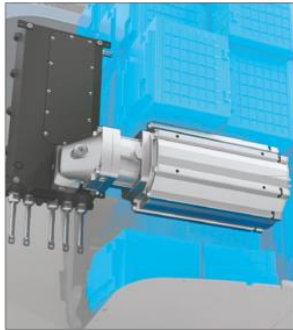



ES10000

**AUTONOMY,
STABILITY, SPACE
MANAGEMENT**

OPTIMAL IN EVERYWAY





CUSTOMER BENEFITS

Switch to
AUTONOMY

LESS TRAVEL,
MORE AUTONOMY



**75KW.H LI-ION
BATTERY**



TECHNICAL DATA

100% electric

75 kW.h capacity

Battery Lithium-ion NMC

8 hours' autonomy

4 hours to charge the batteries

3 electric motors, one for the transmission,
one for the implements and one the swing
system

0 CO₂ and particulate emissions



ED6

**AUTONOMY,
PERFORMANCE,
SAFETY**

**FIRST 100% ELECTRIC
6-TONS SITE DUMPER**









- Main characteristics



Size / Weight: 10 feet / 8T

	Capacity	Charge power
	300kWh	200kW
	150kWh	22kW
	75kWh	22kW
	75kWh	22kW



Vergleich



A 100% ELECTRIC 12MTX WHEEL EXCAVATOR LOADER

A 12MTX:

- SAME KINEMATICS & BOOM
- SAME DIMENSIONS

ELECTRIC POWER





Vergleich



E12



12 MTX

+1600 KG
(+3,528 lbs)

9700 KG
(21,139 lbs)

11300 KG
(24,912 lbs)





POWER SOURCE



12 MTX



e12

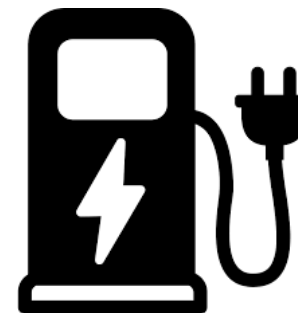
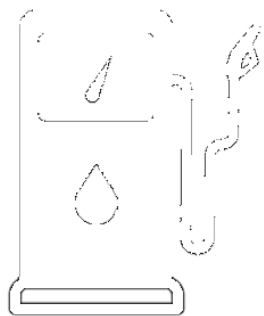



POWER SOURCE

EGr DOWN
DOC SCR TIMES
DPF

12 MTX



e12

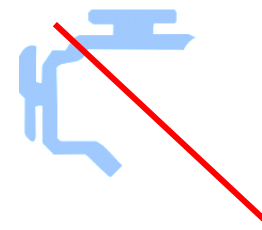
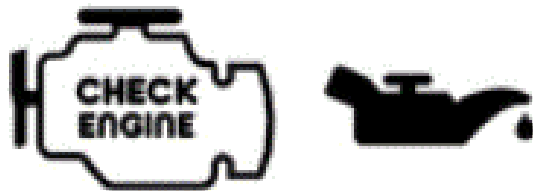

Maintenance: Only the daily greasing and checking of coolant levels.



SOUND LEVELS - EXTERIOR



101 dB



90 dB



÷ 10



SOUND LEVELS - INTERIOR



70 dB



67 dB



÷ 2



POWER



85 kW (115
ch/hp)



150kWh (2x 64 kW)

Operating temperature : - 20°C to +40°C (- 4°F to 104°F)



- Pack batterie 188 kW.h (150 kW.h net) ⑨ Summer : 135 kW.h/jour

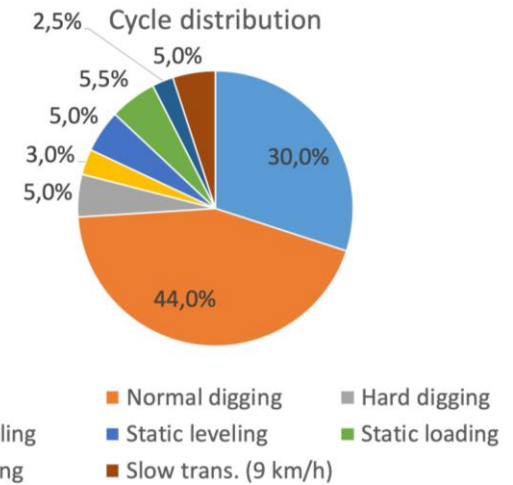
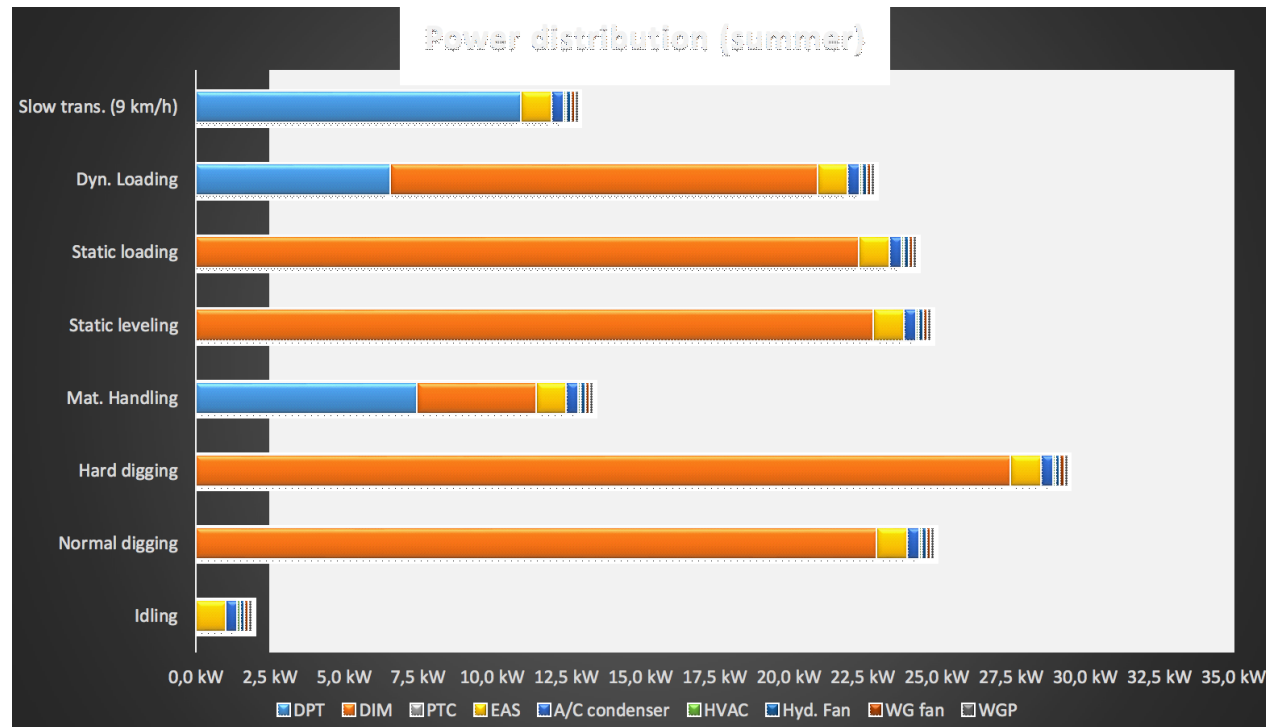

Powertrain Implement Cab heating Cab cooling Fluids cooling

Emissions Greenhouse Gas (CO₂) by day: $8 \text{ h} \times 7,5 \text{ l/h} \times 2,6 \text{ kg CO}_2 / \text{l} = 156 \text{ kg CO}_2$

by year = **34,3 tonnes CO₂**

e12 = 0 !

Emissions small particles (PM) by day : $8 \text{ h} \times 20 \text{ kW} \times 0,025 \text{ g/kWh} = 4 \text{ g PM}$

by year = **880 g PM**

e12 = 0 !

Emissions NO_x by day : $8 \text{ h} \times 20 \text{ kW} \times 0,4 \text{ g/kWh} = 64 \text{ g NO}_x$

by year = **14,1 kg NO_x**

e12 = 0 !

Emissions CO by day : $8 \text{ h} \times 20 \text{ kW} \times 5 \text{ g/kWh} = 800 \text{ g CO}$

by year = **176 kg CO**

e12 = 0 !

Emissions HC by day : $8 \text{ h} \times 20 \text{ kW} \times 0,19 \text{ g/kWh} = 30,4 \text{ g HC}$

by year = **6,7 kg HC**

e12 = 0 !



BATTERIES



BATTERIES

2 IDENTICAL BATTERY MODULE

1250 kg
(2,756 lbs)



- Rated capacity: **150 kWh, 2x 75kWh**
- Technology: **Lithium ion, NMC-type**
- Voltage: **700V**
- Weight: **2x 625 kg (2x 1,378 lbs)**
- Manufacturer: **Northvolt**
- Made in **Europe**
- Autonomy: **8 hrs**

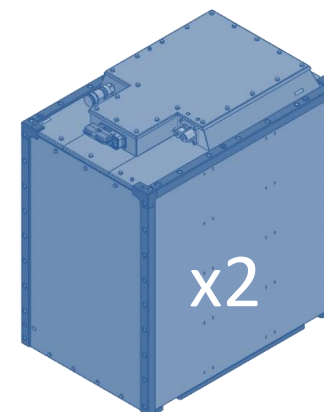



BATTERIES MODULE

EACH MODULE INCLUDES:

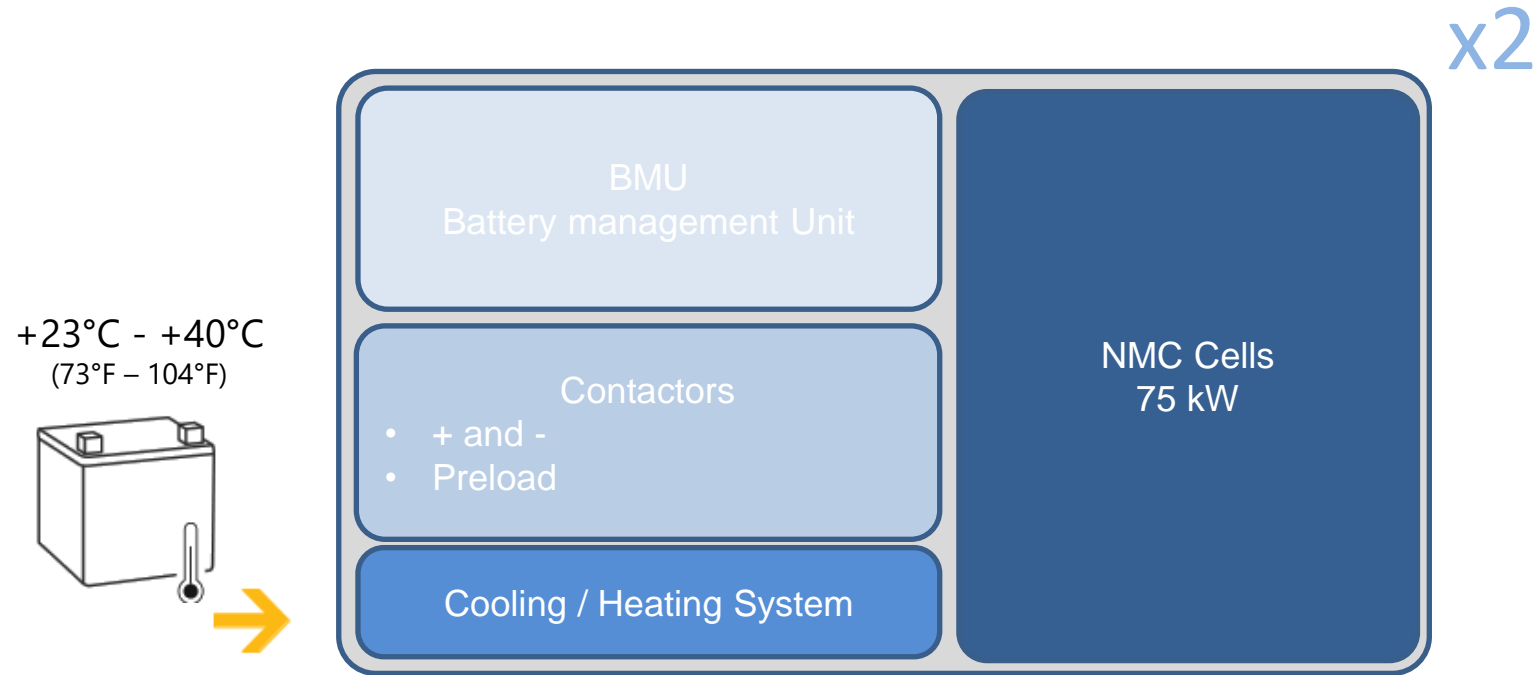

**BATTERY KEPT AT THE BEST OPERATING TEMPERATURE:
ENHANCED LIFESPAN**



THERMIC CONTROL

& energy availability at all temperatures

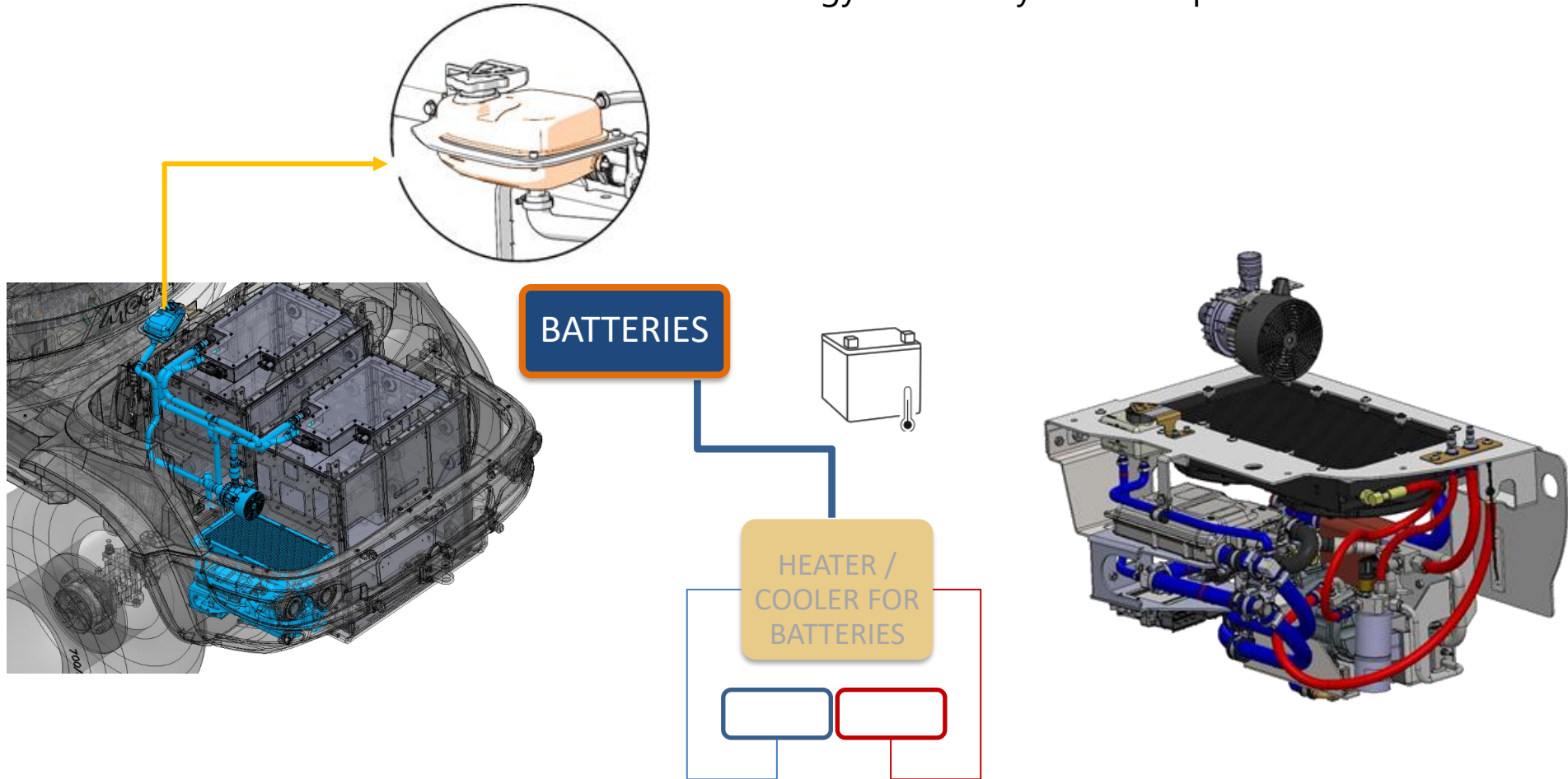

**BATTERY KEPT AT THE BEST OPERATING TEMPERATURE:
ENHANCE LIFESPAN**



HOW DOES IT WORK?



ELECTRIC POWER AND HYDRAULIC OUTFLOW

IMPLEMENTS:

1 motor, 1 pump

TRANSMISSION:

1 motor



**TWO INDEPENDENT CIRCUITS
BETTER COMBINED MOVEMENTS**



ARCHITECTURE – IMPLEMENTS / AUXILIARY

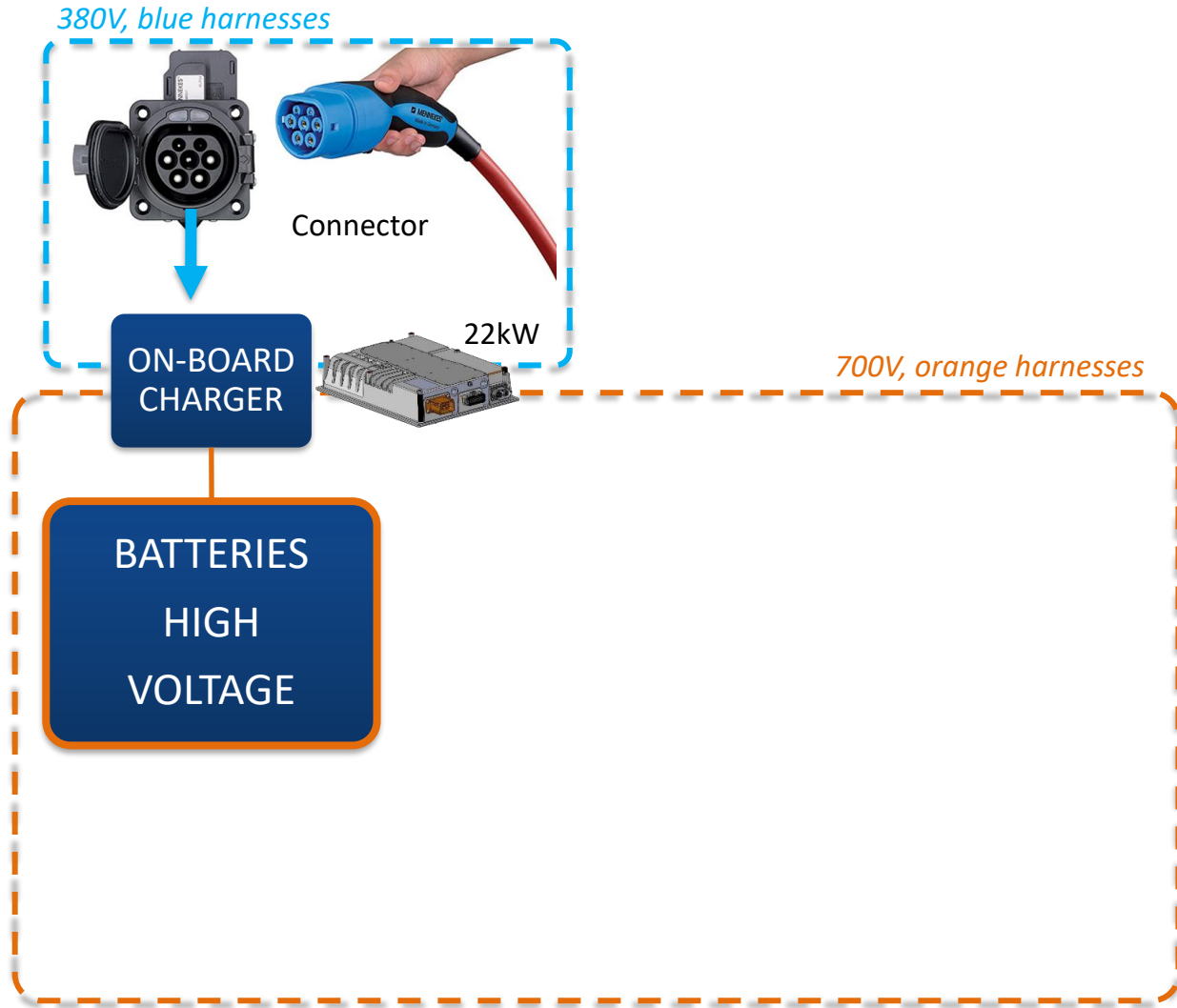



ARCHITECTURE – IMPLEMENTS / AUXILIARY

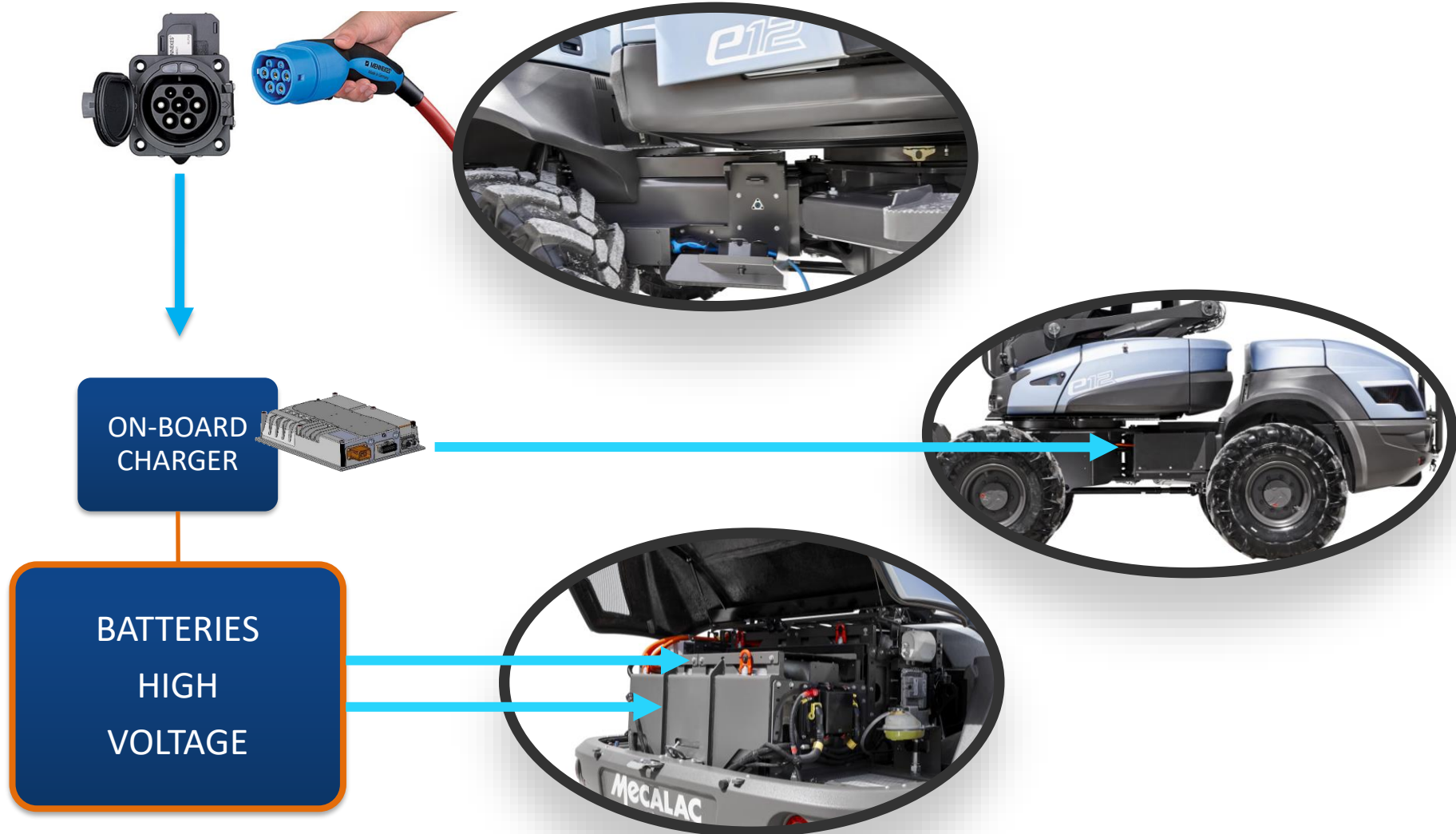



ARCHITECTURE – IMPLEMENTS / AUXILIARY

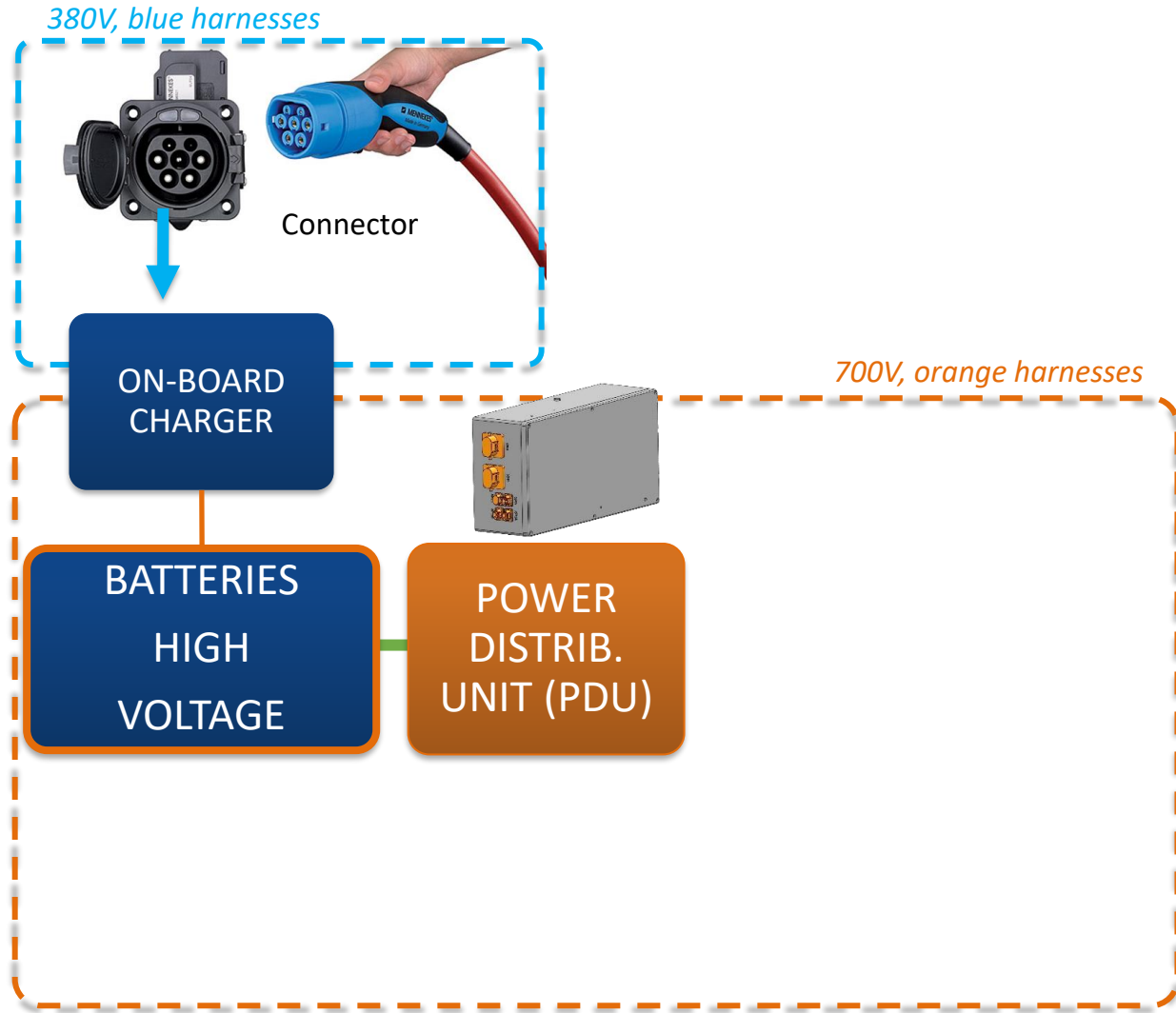



ARCHITECTURE – IMPLEMENTS / AUXILIARY



ON-BOARD CHARGER

BATTERIES
HIGH VOLTAGE

POWER
DISTRIB.
UNIT (PDU)





ARCHITECTURE – IMPLEMENTS / AUXILIARY

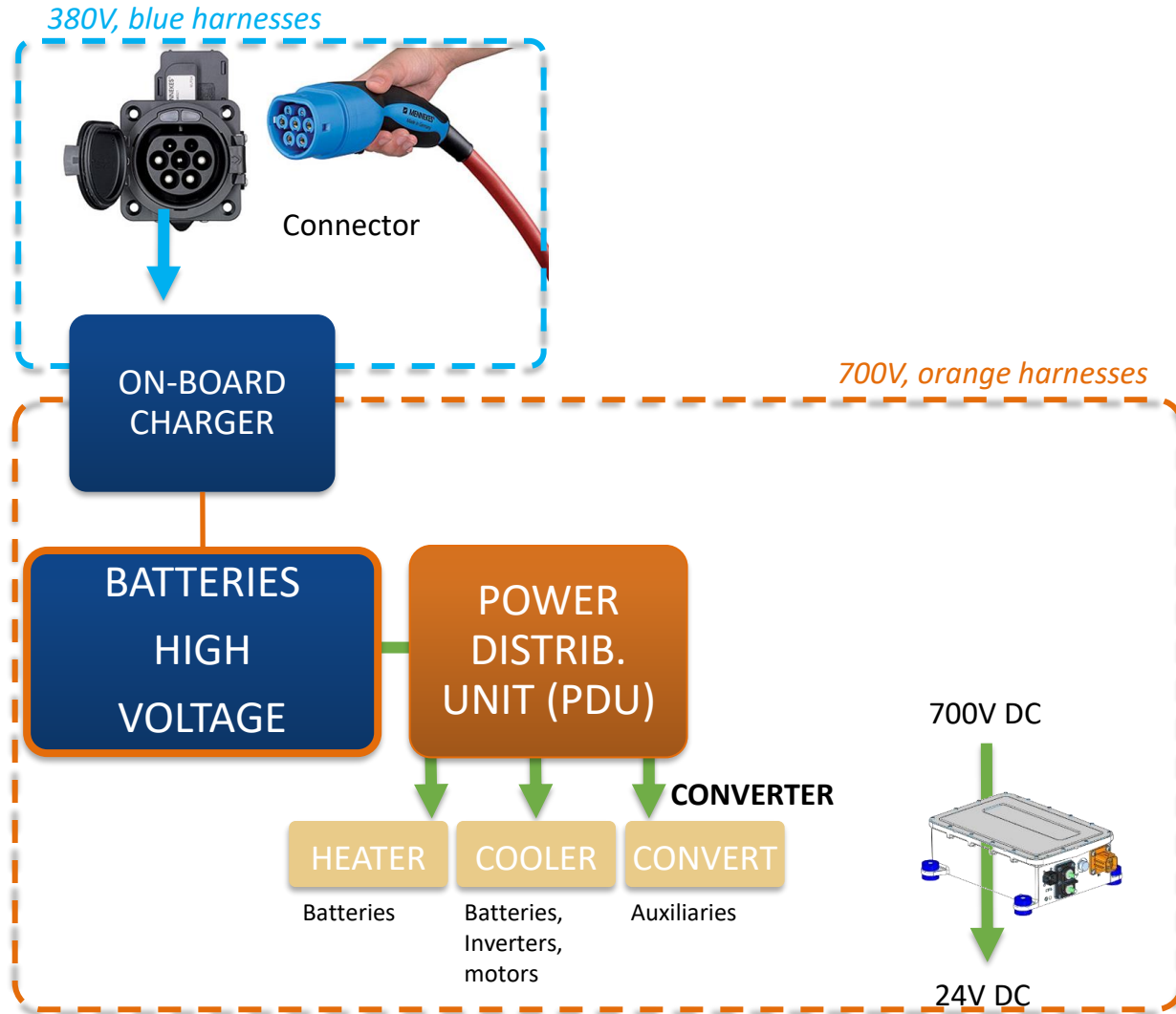



ARCHITECTURE – IMPLEMENTS / AUXILIARY

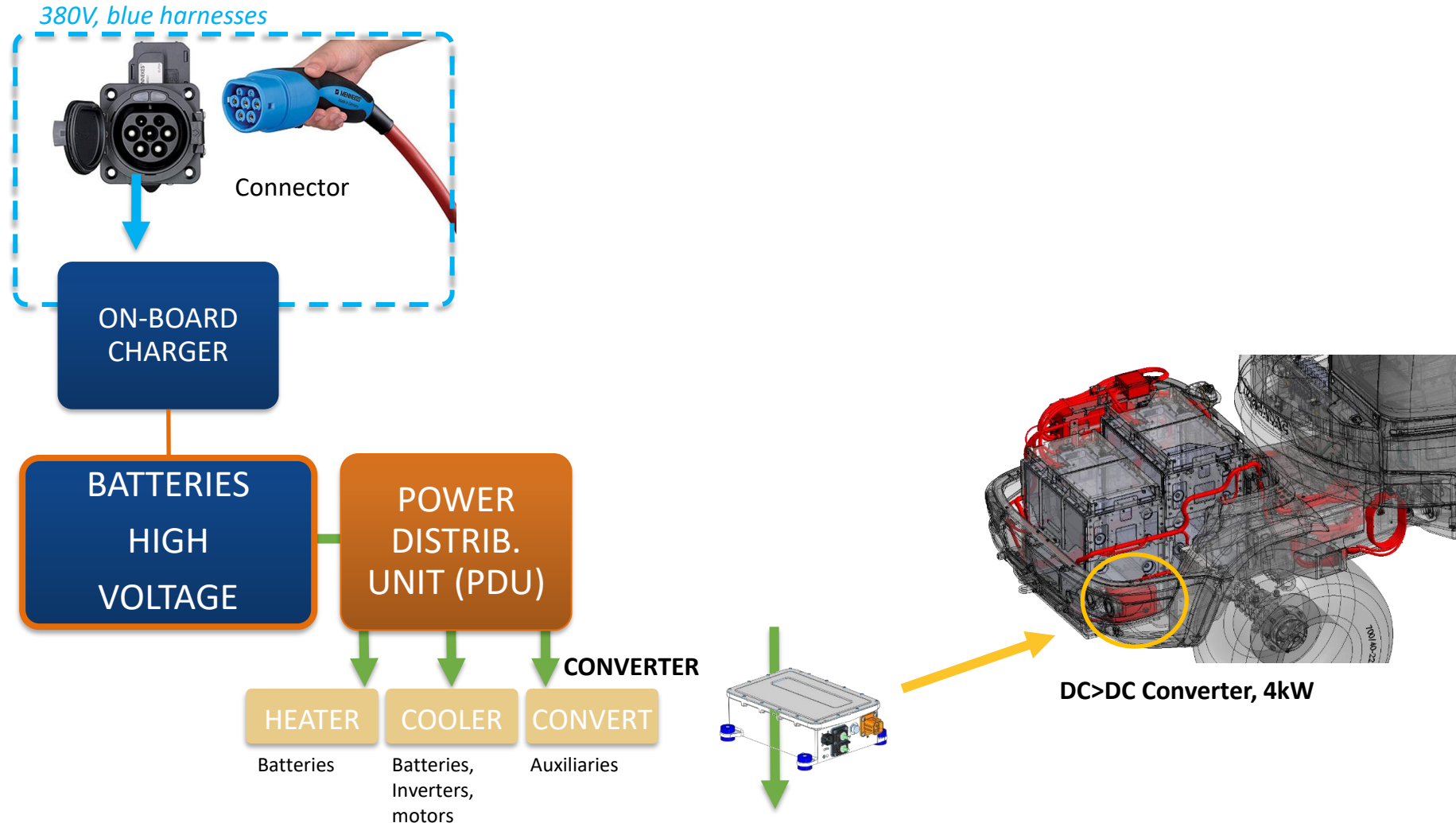



ARCHITECTURE – IMPLEMENTS / AUXILIARY

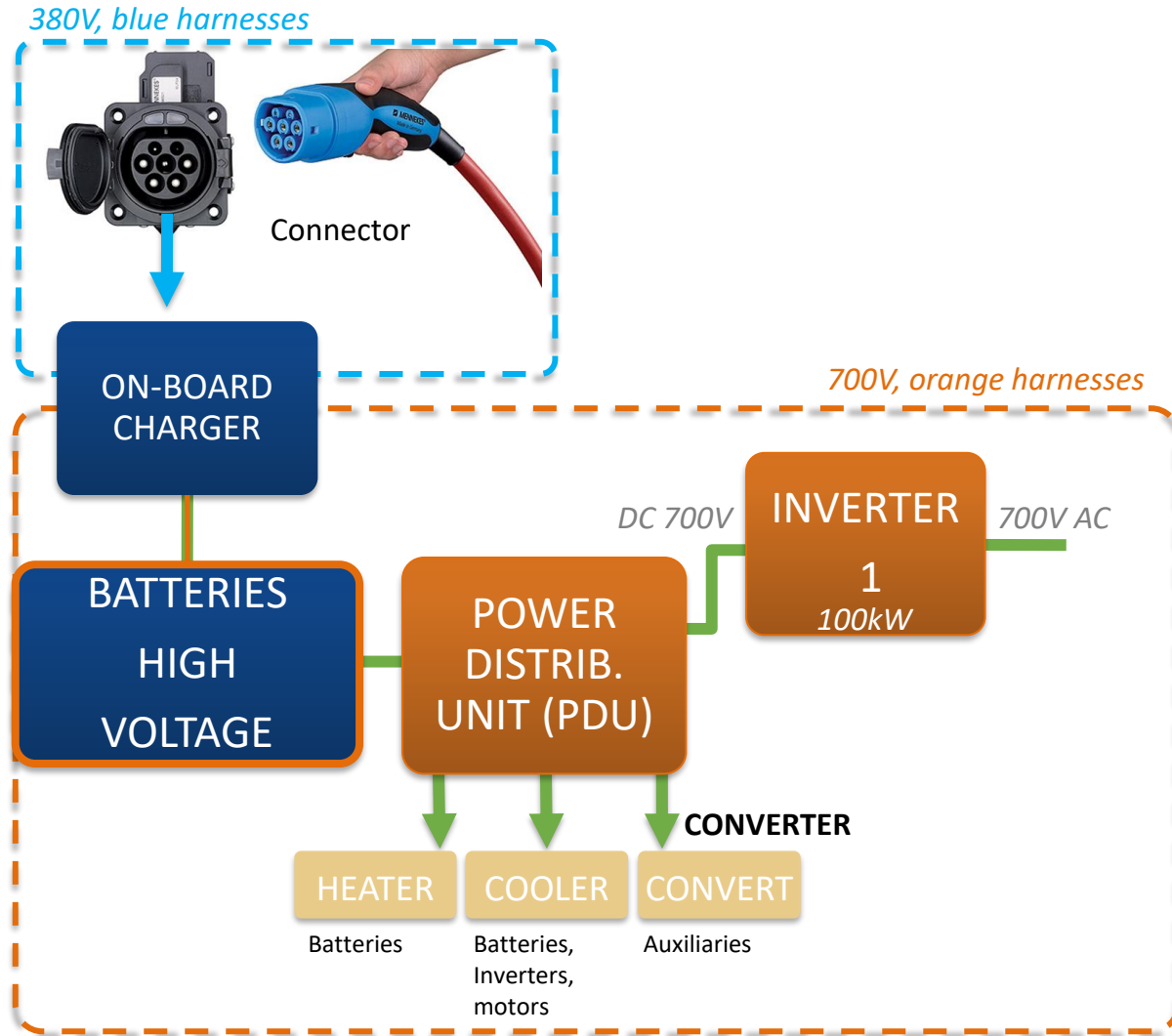



ARCHITECTURE – IMPLEMENTS / AUXILIARY



ON-BOARD CHARGER

BATTERIES HIGH VOLTAGE

POWER DISTRIB. UNIT (PDU)

INVERTER
1
100kW

DC 700V

HEATER

Batteries

COOLER

Batteries, Inverters, motors

CONVERTER

CONVERT

Auxiliaries

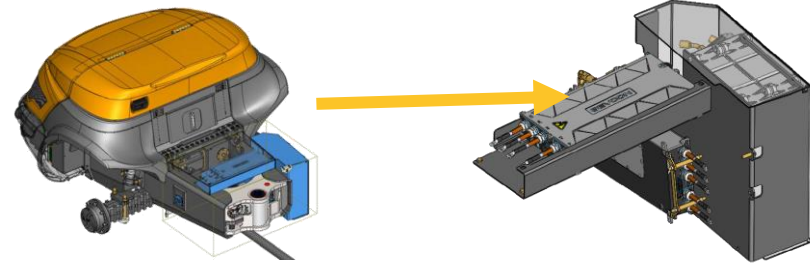

- INVERTER:**
- Sets engine speed & torque depending on the need
 - Transforms DC > AC



ARCHITECTURE – IMPLEMENTS / AUXILIARY

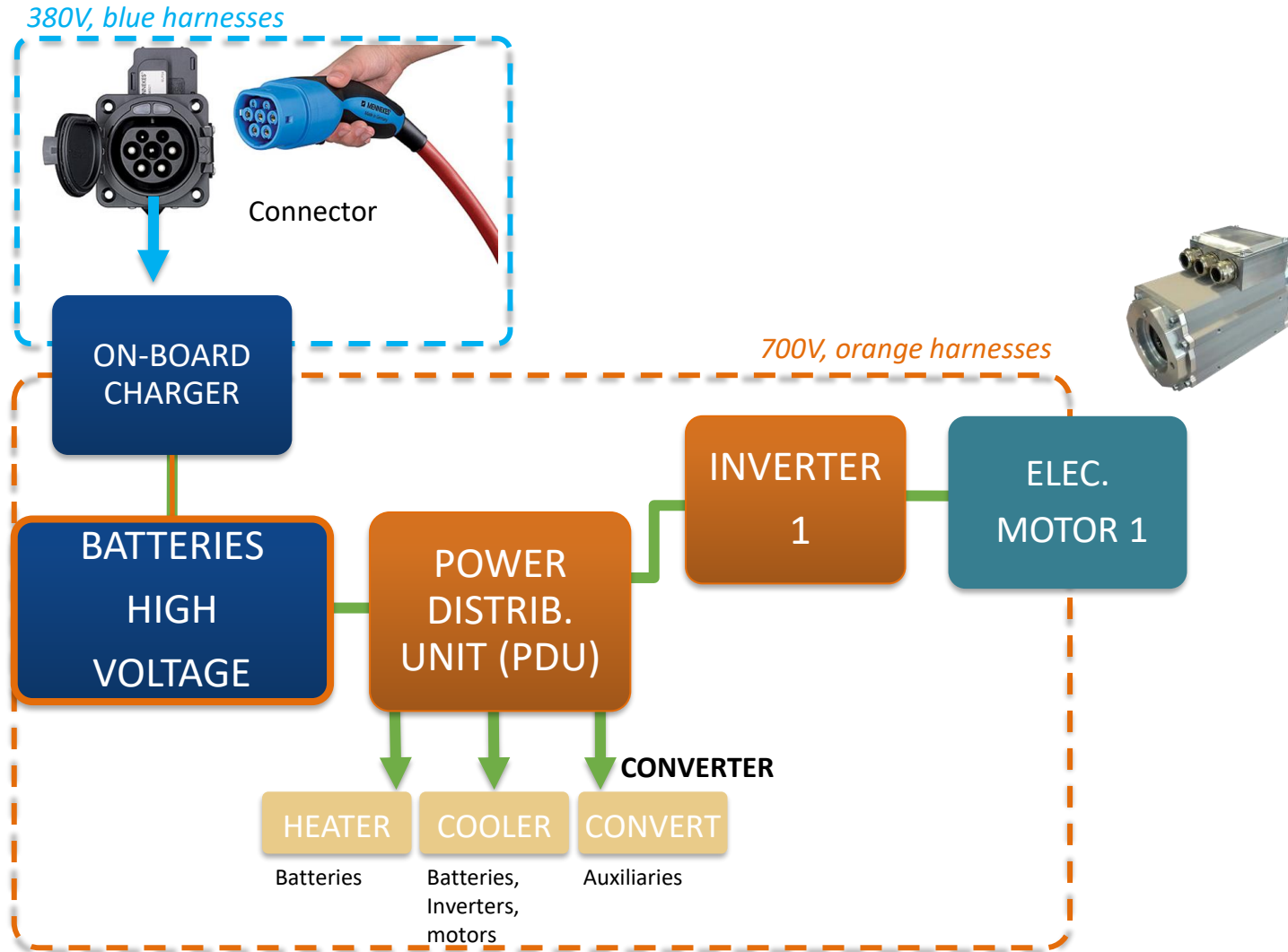



ARCHITECTURE – IMPLEMENTS / AUXILIARY

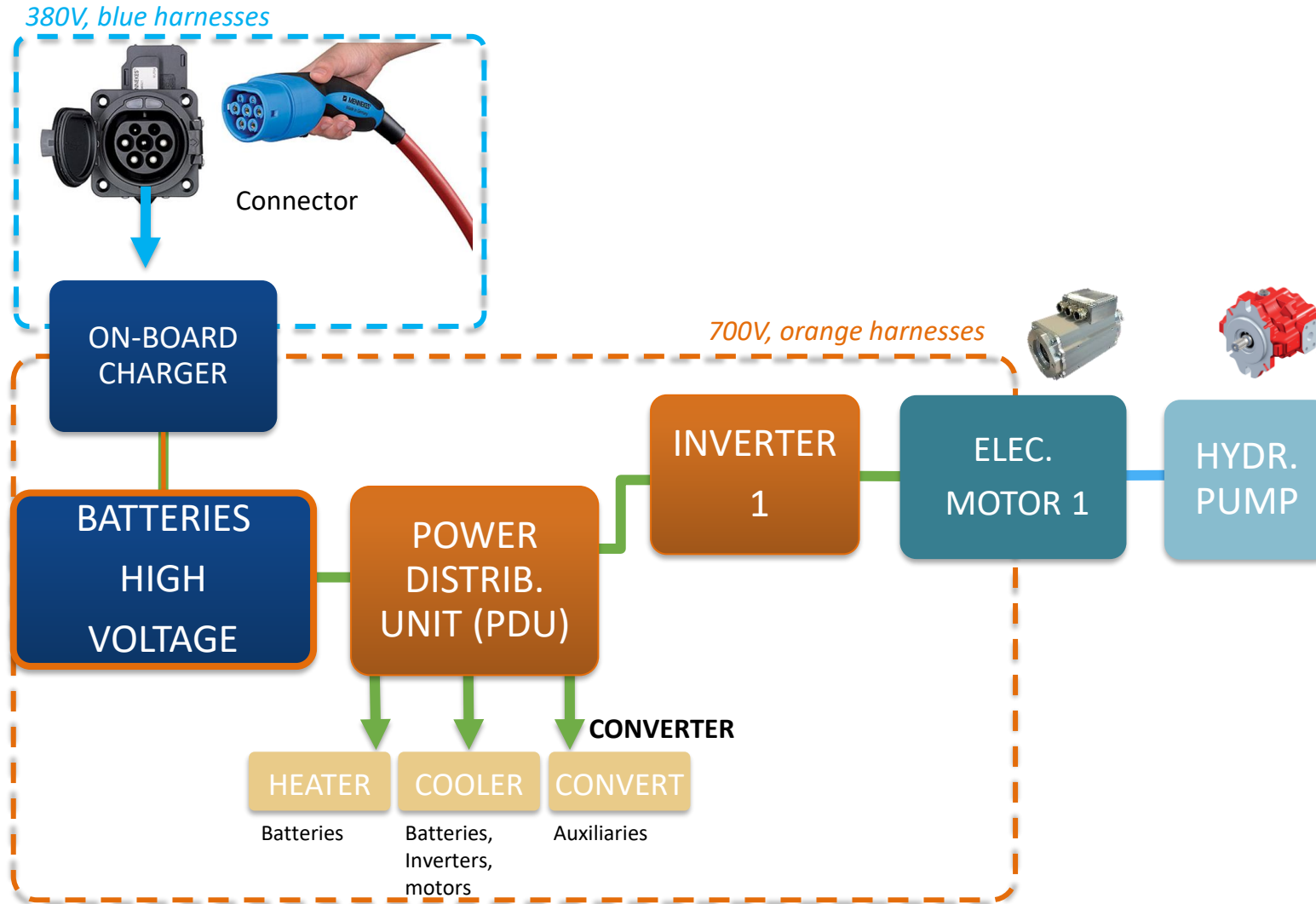



ARCHITECTURE – IMPLEMENTS / AUXILIARY

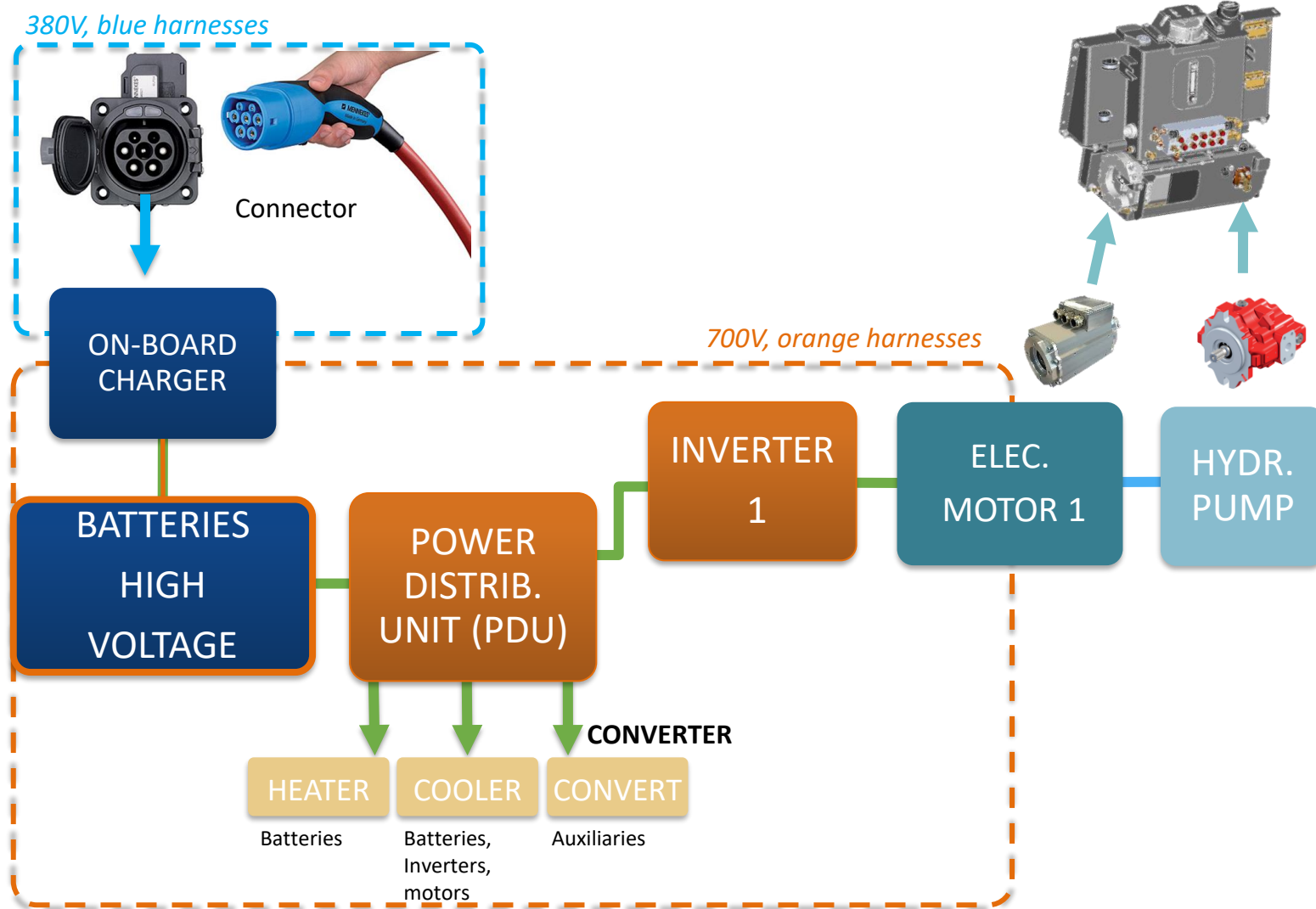



ARCHITECTURE – IMPLEMENTS / AUXILIARY

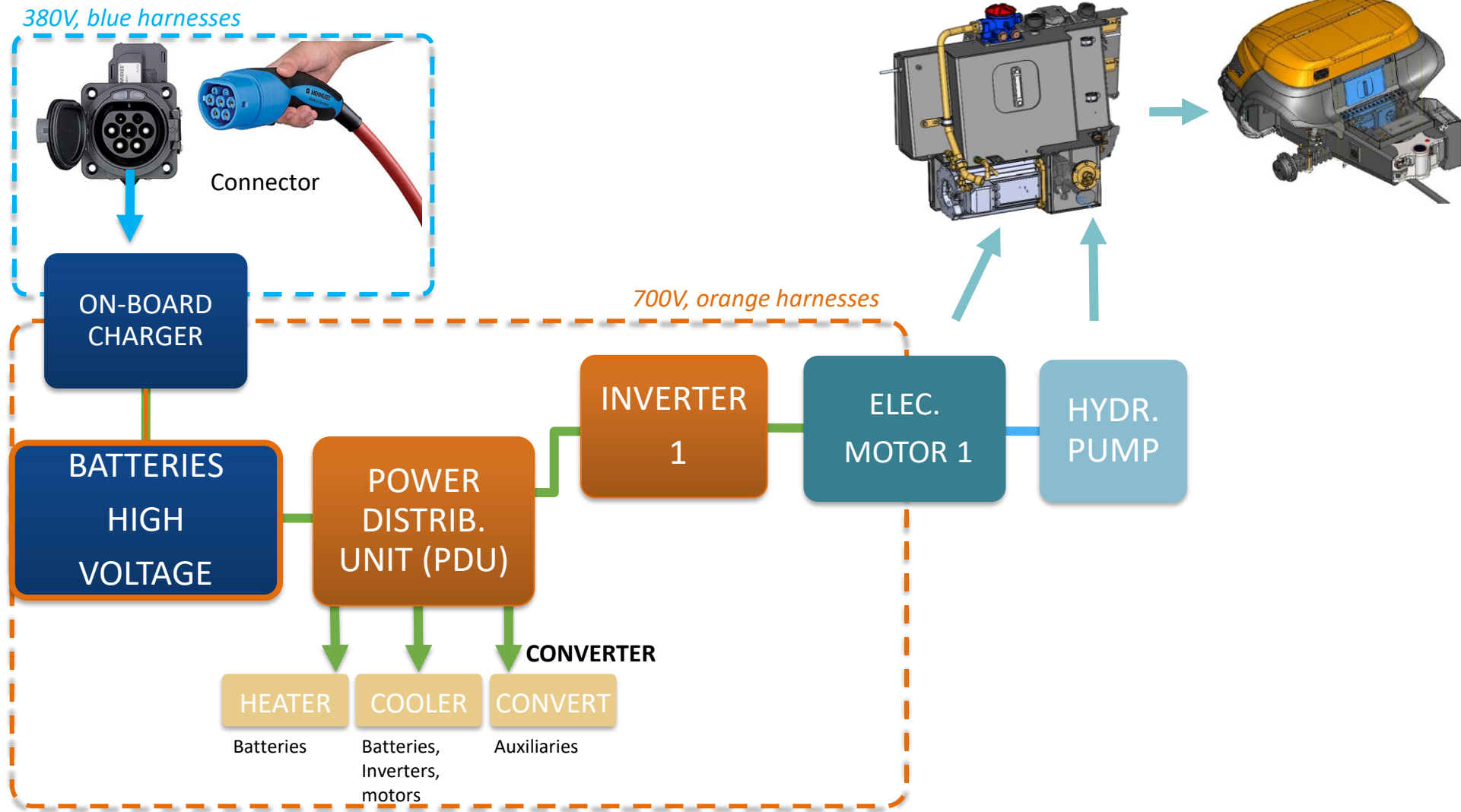



ARCHITECTURE – IMPLEMENTS / AUXILIARY

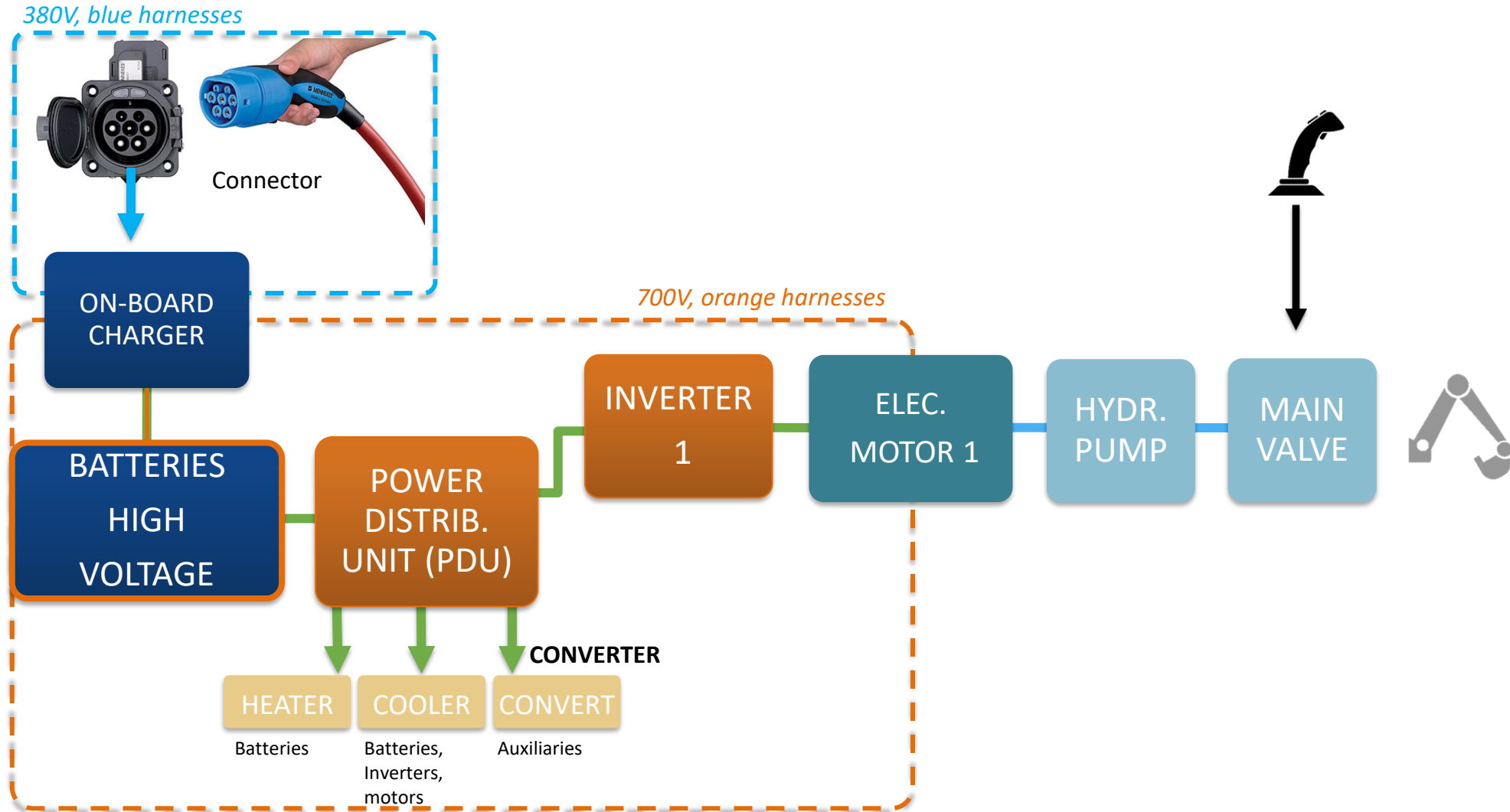



ARCHITECTURE – TRANSMISSION

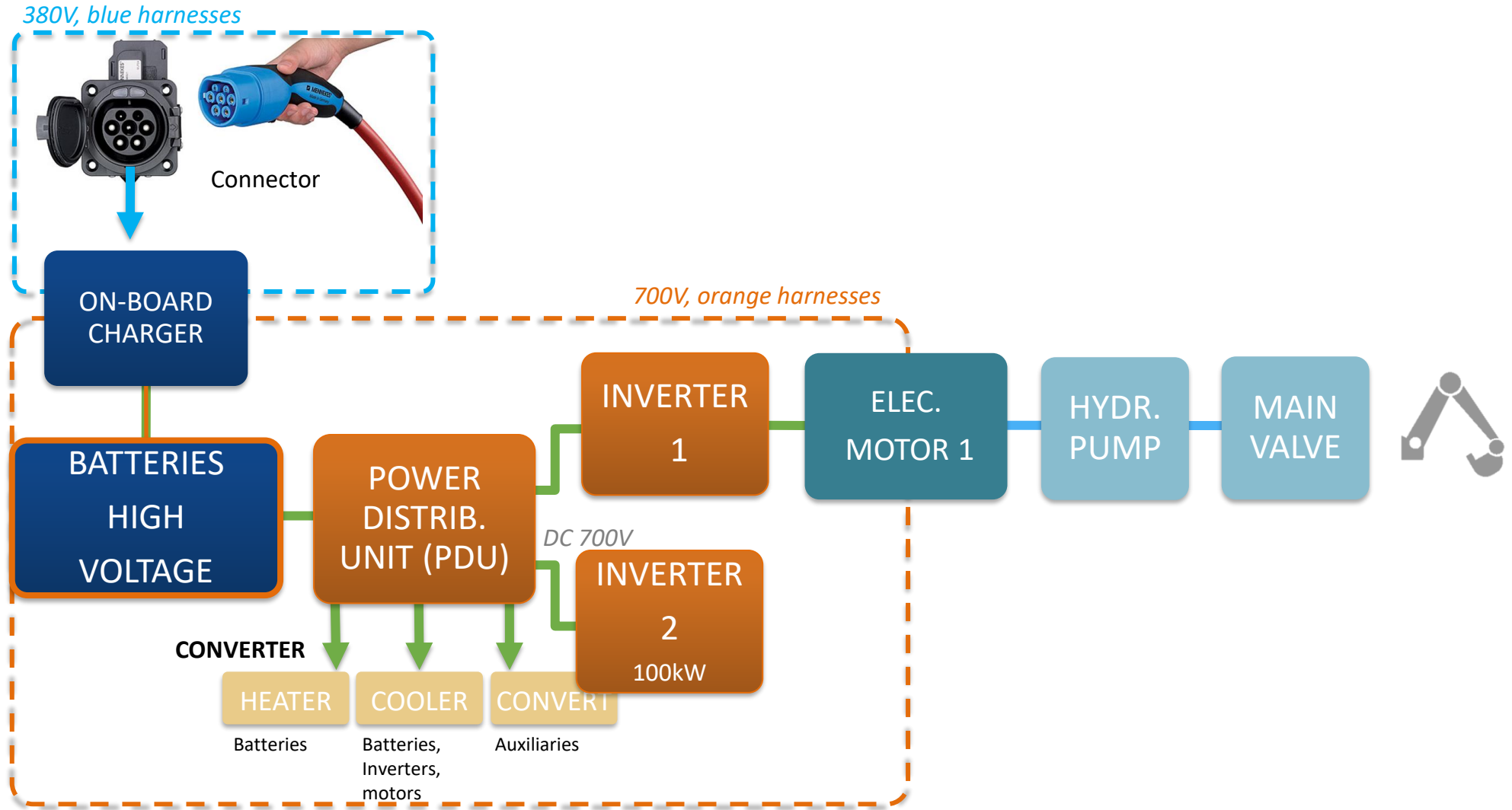



ARCHITECTURE – TRANSMISSION

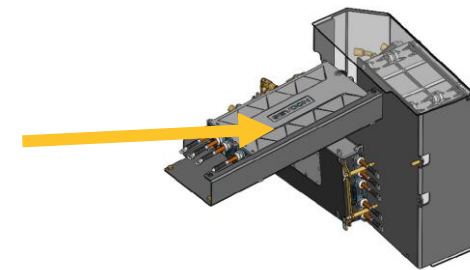
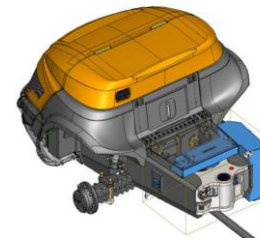
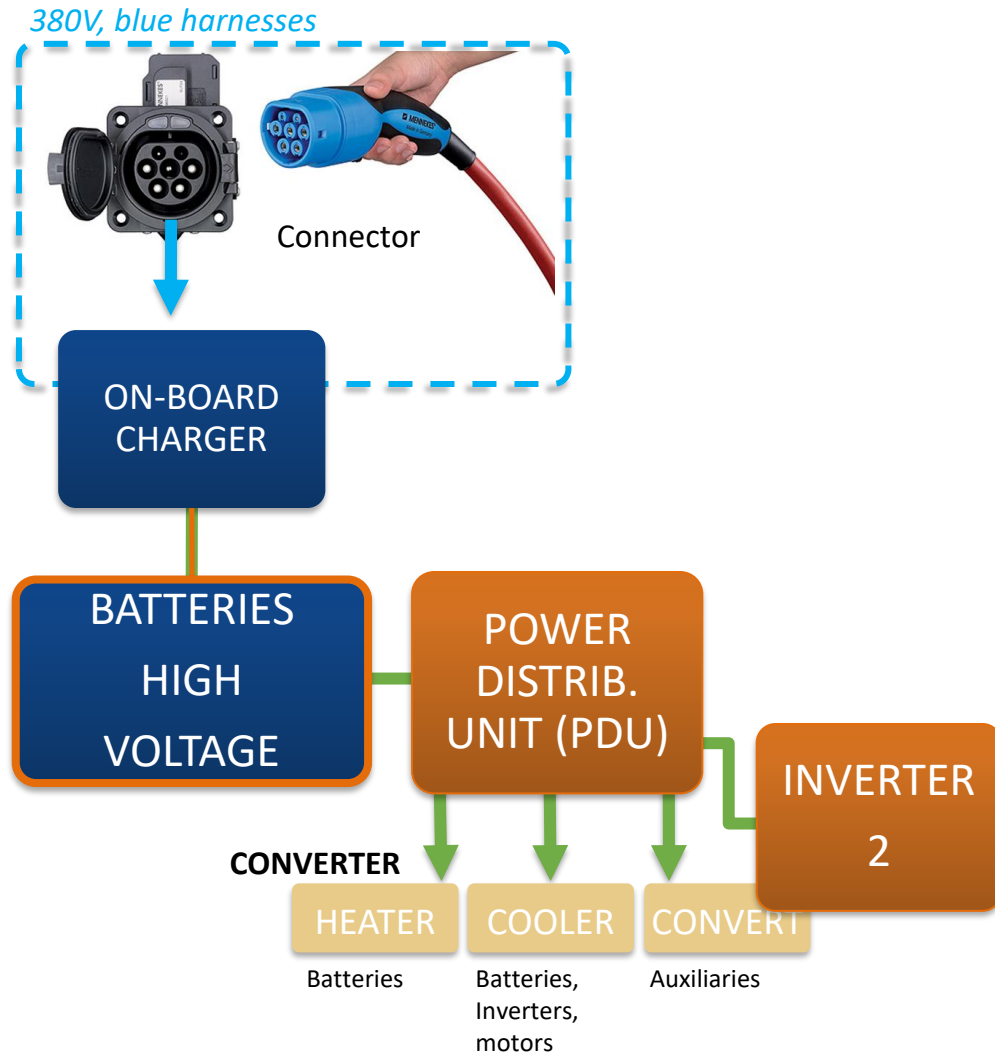



ARCHITECTURE – TRANSMISSION

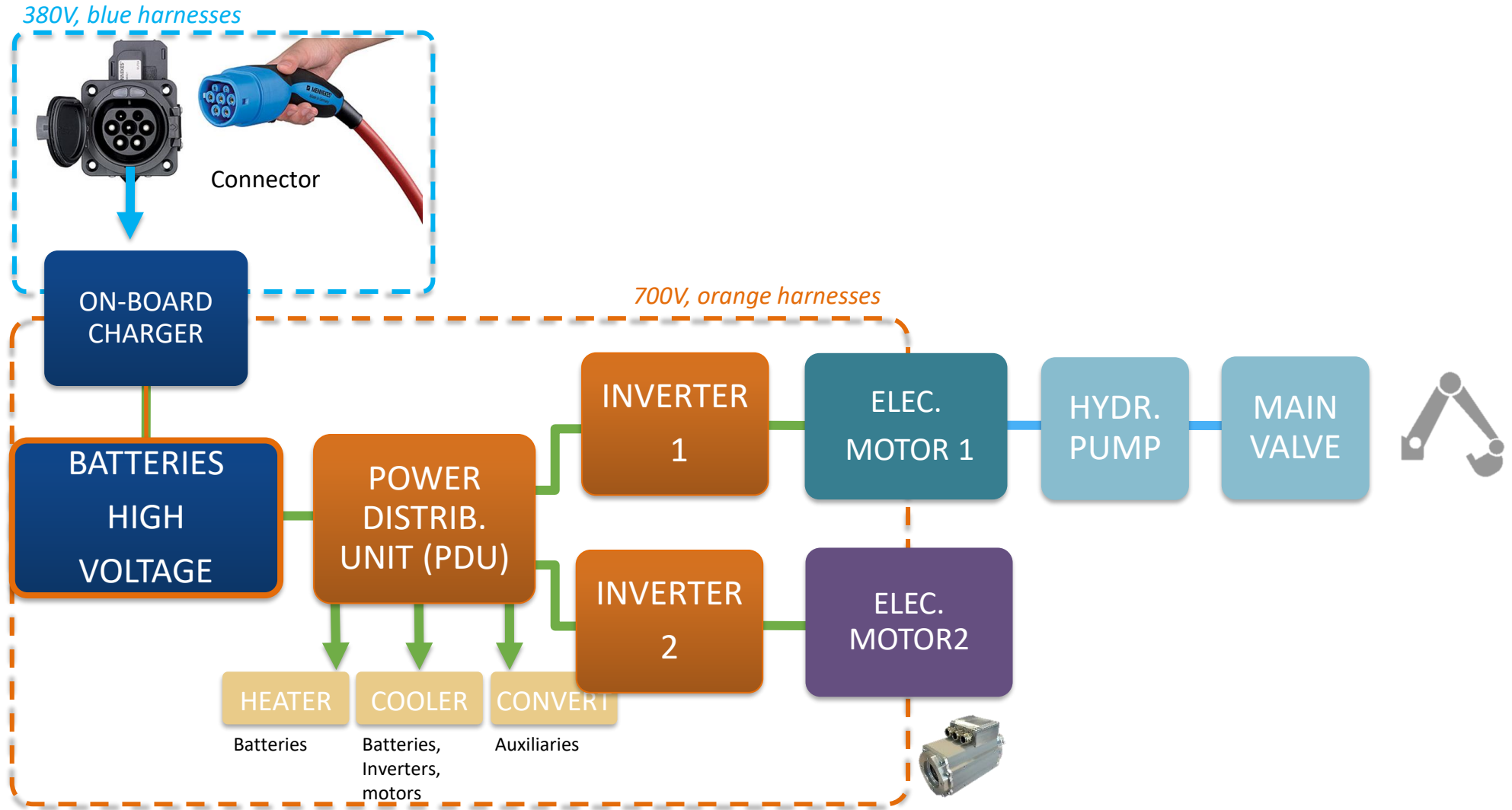



ARCHITECTURE – TRANSMISSION

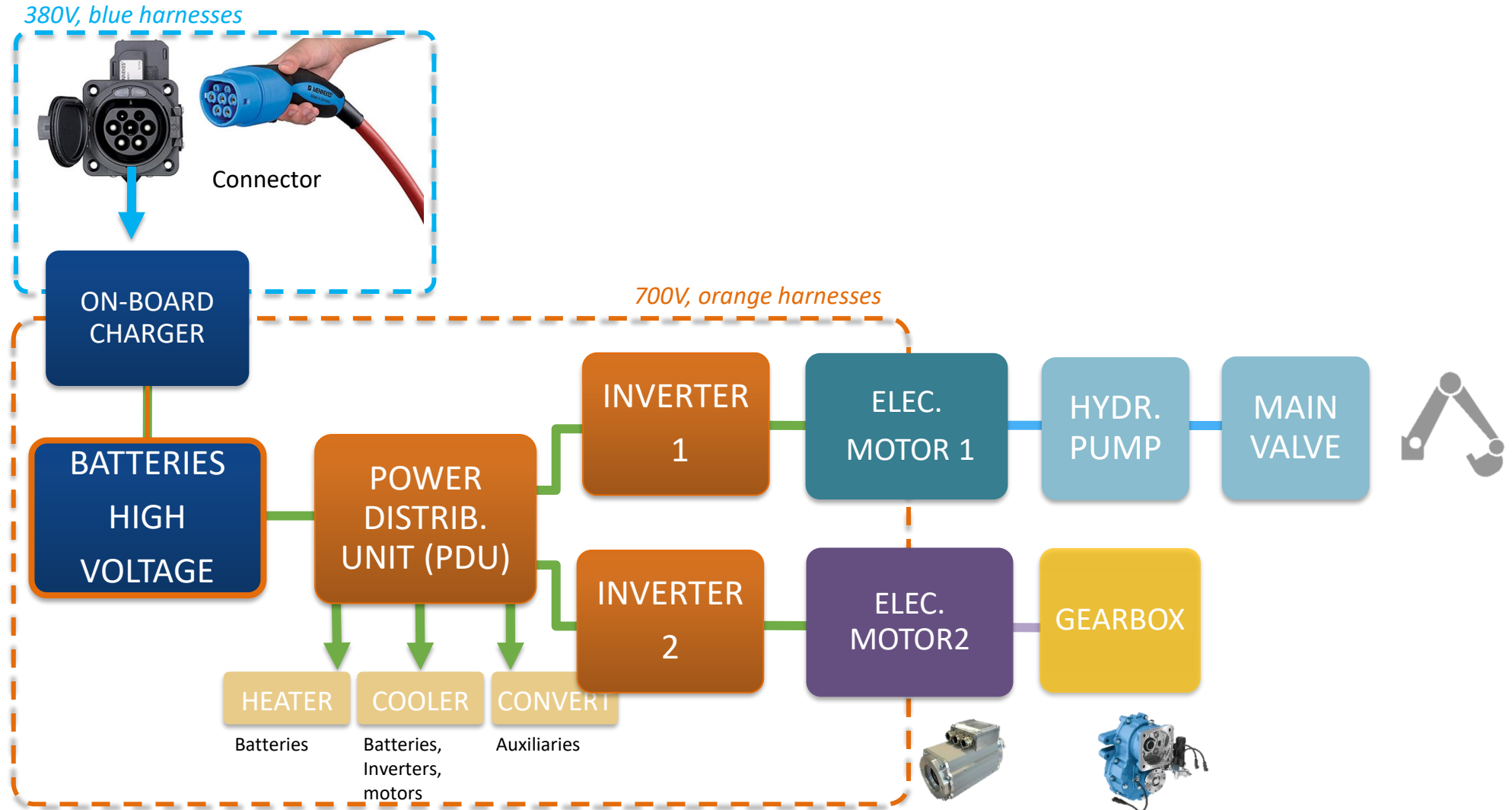



ARCHITECTURE – TRANSMISSION

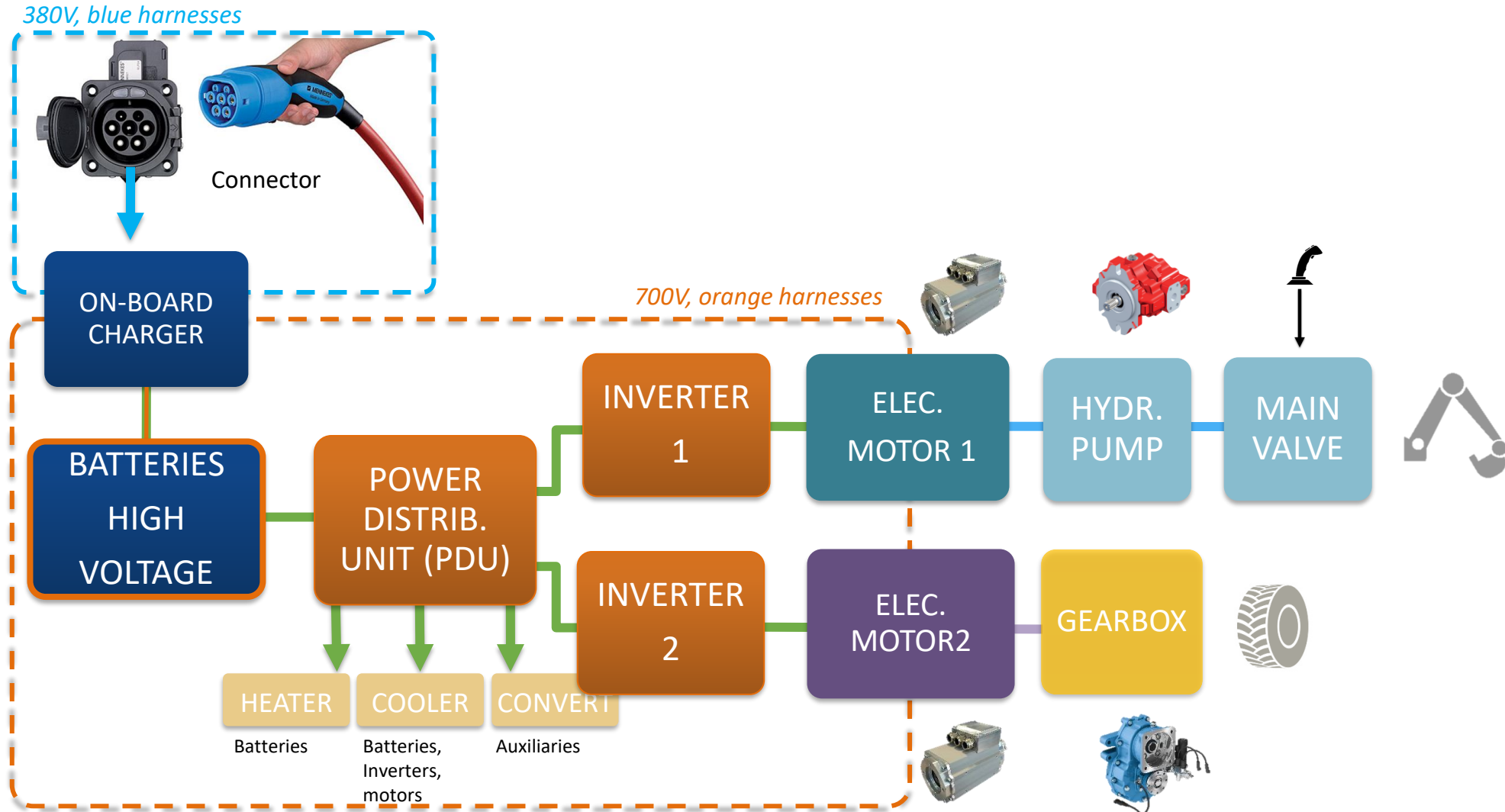



POWER - COMPONENTS

IMPLEMENTS:

- 1 electric inverter, *SEVCON*
- 1 electric motor, *PARKER*, 64 kw | 171Nm (126 lbf.ft)
- 1 pump, *BUCHER*, fix displacement, 144 L/min (38 gpm) | 300bar (4,500 psi)



TRANSMISSION:

- 1 electric inverter, *SEVCON*
- 1 electric motor, *PARKER*, 64 kw | 171Nm (126 lbf.ft)
- 1 mechanical gearbox, *DANA* Shift-on-Fly, 2 auto. gears





CHARGING



CHARGING DEVICES

! POWER SOURCE MUST BE PROTECTED BY A 40A **B-TYPE** DIFFERENTIAL.



Socket: Type 2 (automotive-type charging station)

Recommended 22kW power source (for a full charge of 8 hrs)

Basic cable with a type-2 plug at each end

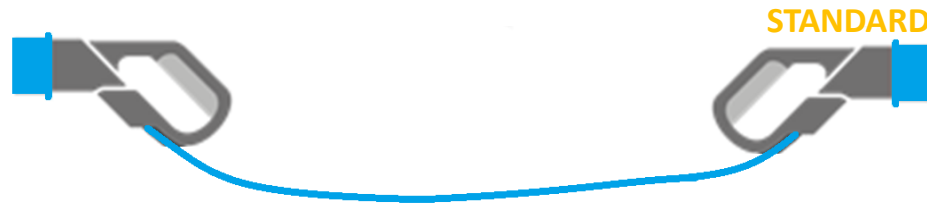

Socket Type 2



Socket: 5-pin industrial (3P+T+N)

Power source: 32A 380V (indicative power 22kW)

The cable includes a charger module to manage the flow

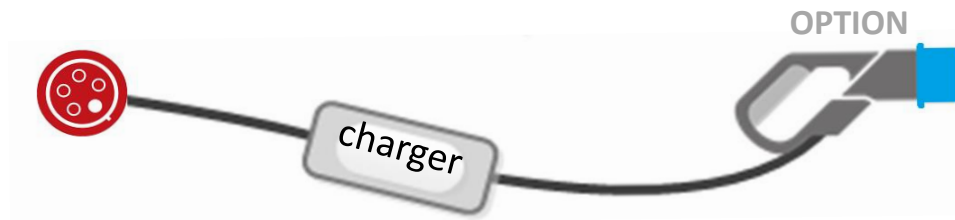



OPERATING TIPS HOW TO?



HOW TO... START THE MACHINE

1. Key-on
2. Press the brake pedal
(release & press again if needed)
3. Press button START

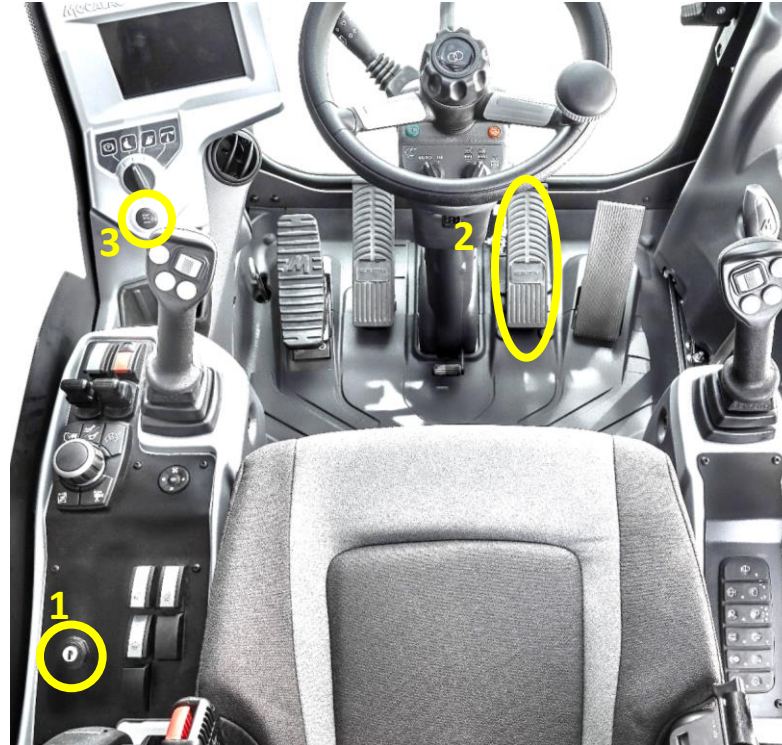

Once started, the machine makes "no sound": except for the heating/cooling systems, no motor or pump turns as long as no control are activated.



HOW TO... STOP & CHARGE THE MACHINE

1. Press button STOP
2. Key-off
3. Wait 30 sec.
(until all sys. are fully stopped)
4. Open the plug compartment
5. Plug the socket

Do **NOT** turn **OFF** the low voltage battery disconnect switch or the charge won't work !



The charging is going well if:

LEDs above the socket are **BLUE**, NOT green.

Dashboard: A pictogram appears with a battery connected to a plug.



HOW TO... STOP CHARGING

1. Press the BLUE button

The electricity flow is interrupted to prevent arcing, and the plug is mechanically unlocked.

2. Unplug the socket on the machine side

3. Unplug the socket on the charger side

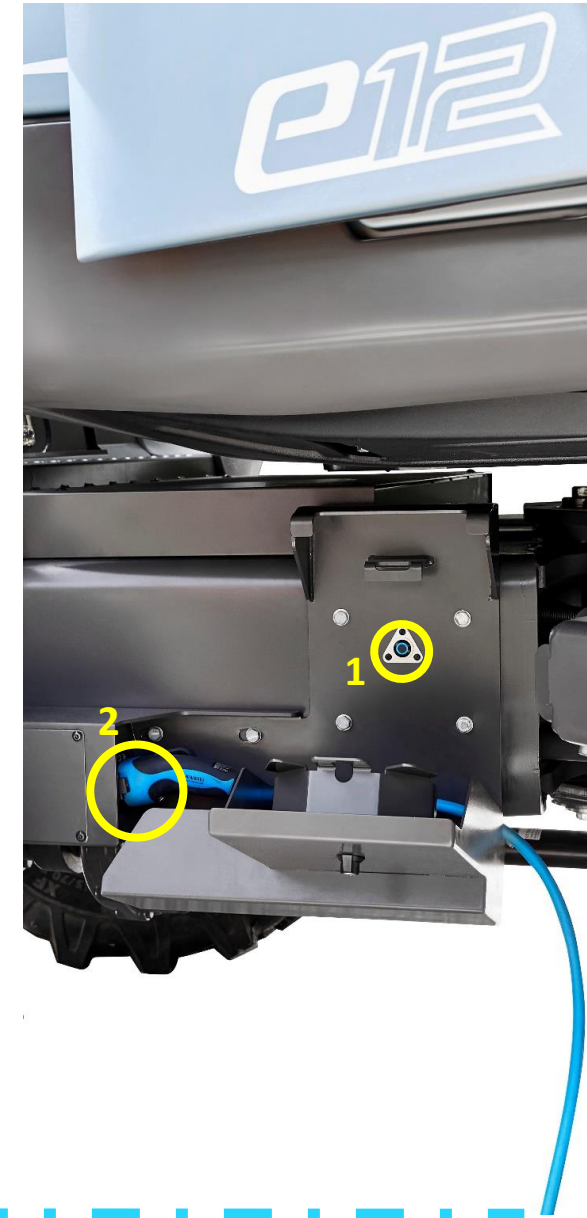

↘ AS1000



ES1000

Möglichst viele Gleichteile zwischen AS1000 und ES1000



AS1000



Bedienung
Radlader



Technik AS1000

Dieselmotor 55,4 kW

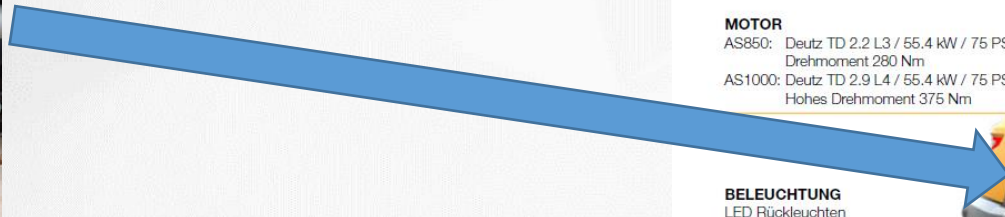

AS850-AS1000

KABINE AS850/1000
2 Türen

MOTOR
AS850: Deutz TD 2.2 L3 / 55.4 kW / 75 PS
Drehmoment 280 Nm
AS1000: Deutz TD 2.9 L4 / 55.4 kW / 75 PS
Hohes Drehmoment 375 Nm

BELEUCHTUNG
LED Rückleuchten

HYDRAULIK
AS850: 84 l/min / 230 bar
AS1000: 84 l/min / 230 bar
High flow optional

RADSTAND
1980 mm

SCHAUFELARM
Neue Generation

KINEMATIK UND SCHNELLWECHSLER
"Z-Kinematik"
Mecalac Schnellwechsler

SCHAUFELVOLUMEN
AS850: 850 Liter
AS1000: 1000 Liter

STANDARDBREITE
AS850: 1950 mm
AS1000: 2100 mm



5 Hydraulikpumpen:

- Fahren
 - Speisepumpe: Parkbremse, Vorsteuerdruck, Differentialsperre
- Lenkung / Schaufelarm / Anbaugeräte
- Schwenkwerk
- Lüfter

↘ TECHNIK AS1000



Dieselmotor 55,4 kW @ 2300 rpm

TECHNIK AS1000

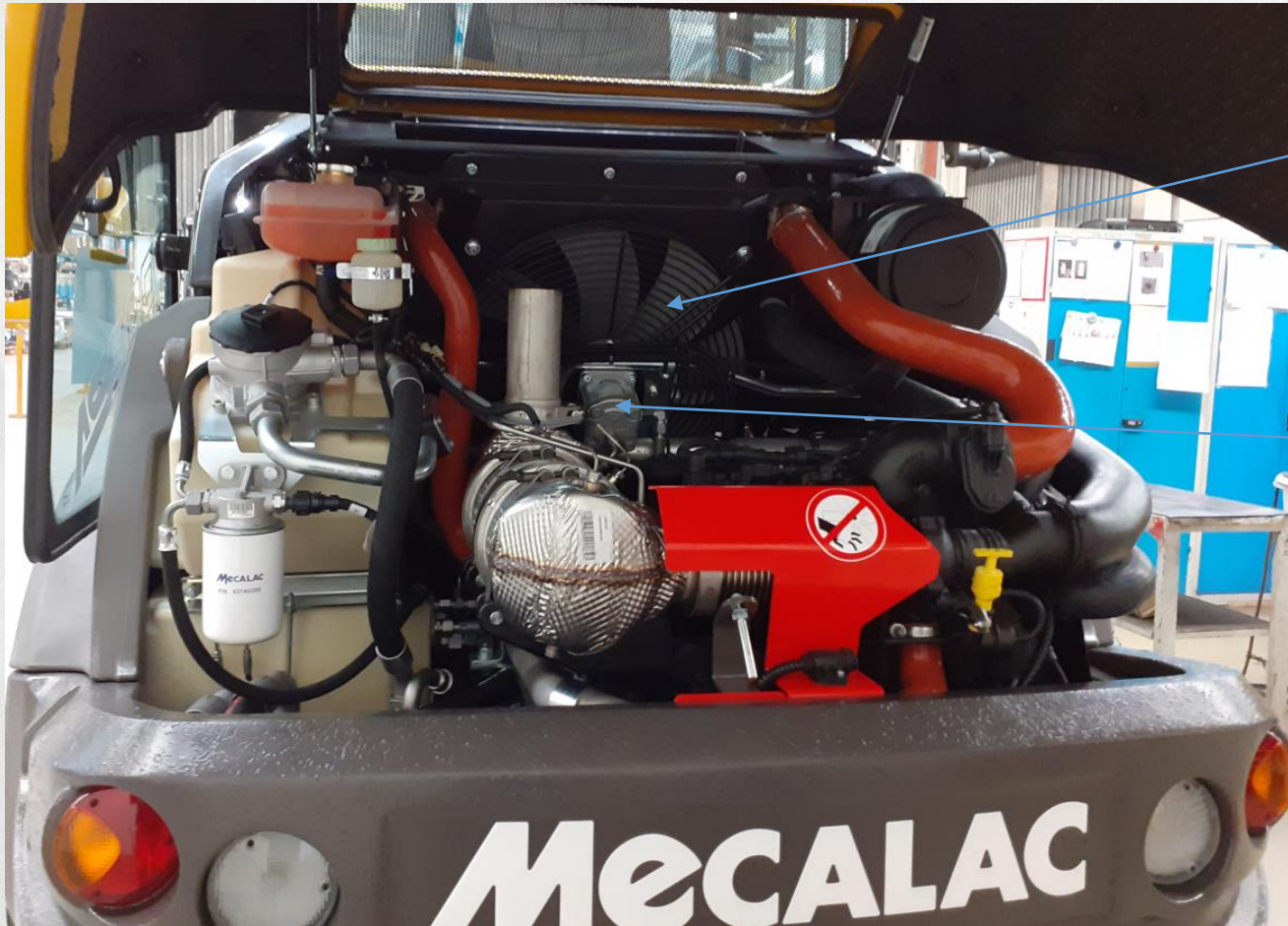

Kühlwasser 42 kW
Ladeluft 13 kW
Hydrauliköl 17kW

Hydraulikmotor 6 kW



Fahrantrieb AS1000 20 km/h

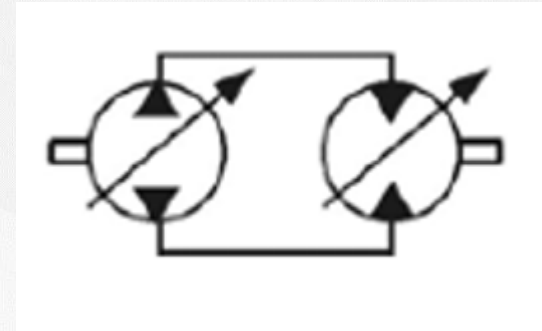
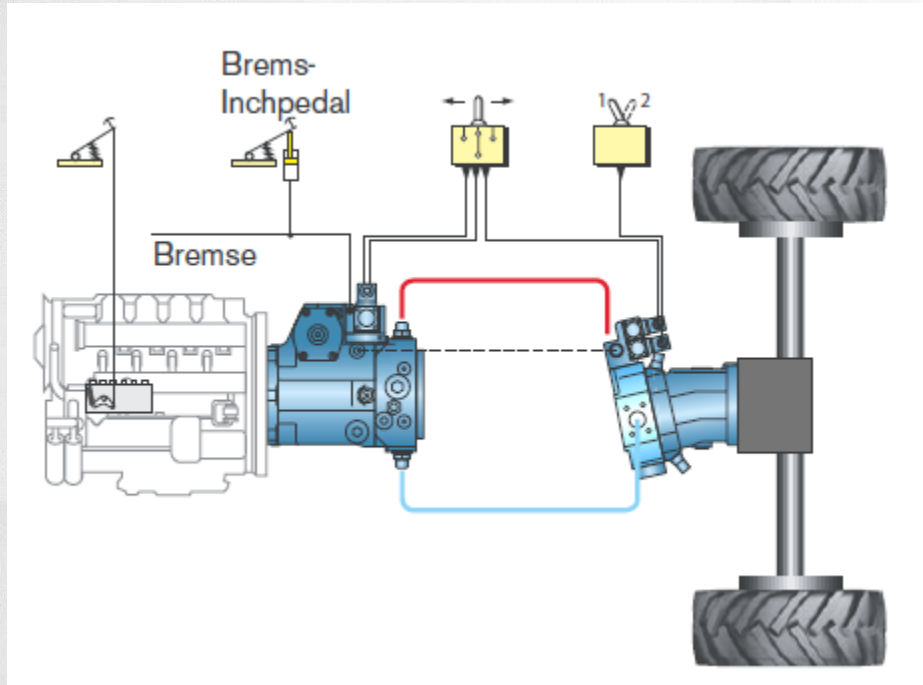



Fahrtrieb AS1000 40 km/h

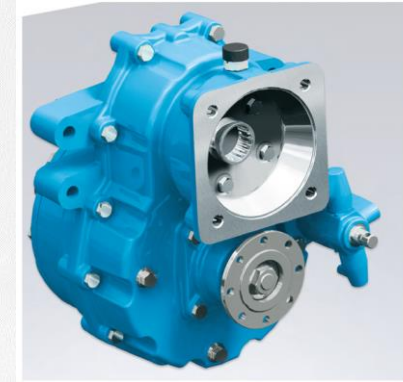
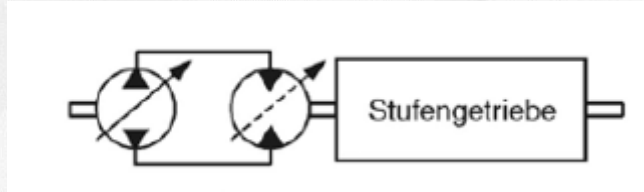

Fahrtrieb AS1600 / AS210 40 km/h

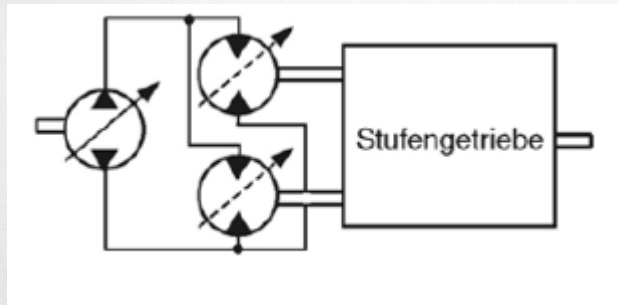



Änderungen ES1000

Nur im hinteren Bereich Änderungen am Fahrgestell Rahmen und an der „Kühlbox“
Achsen und Getriebe sind neu

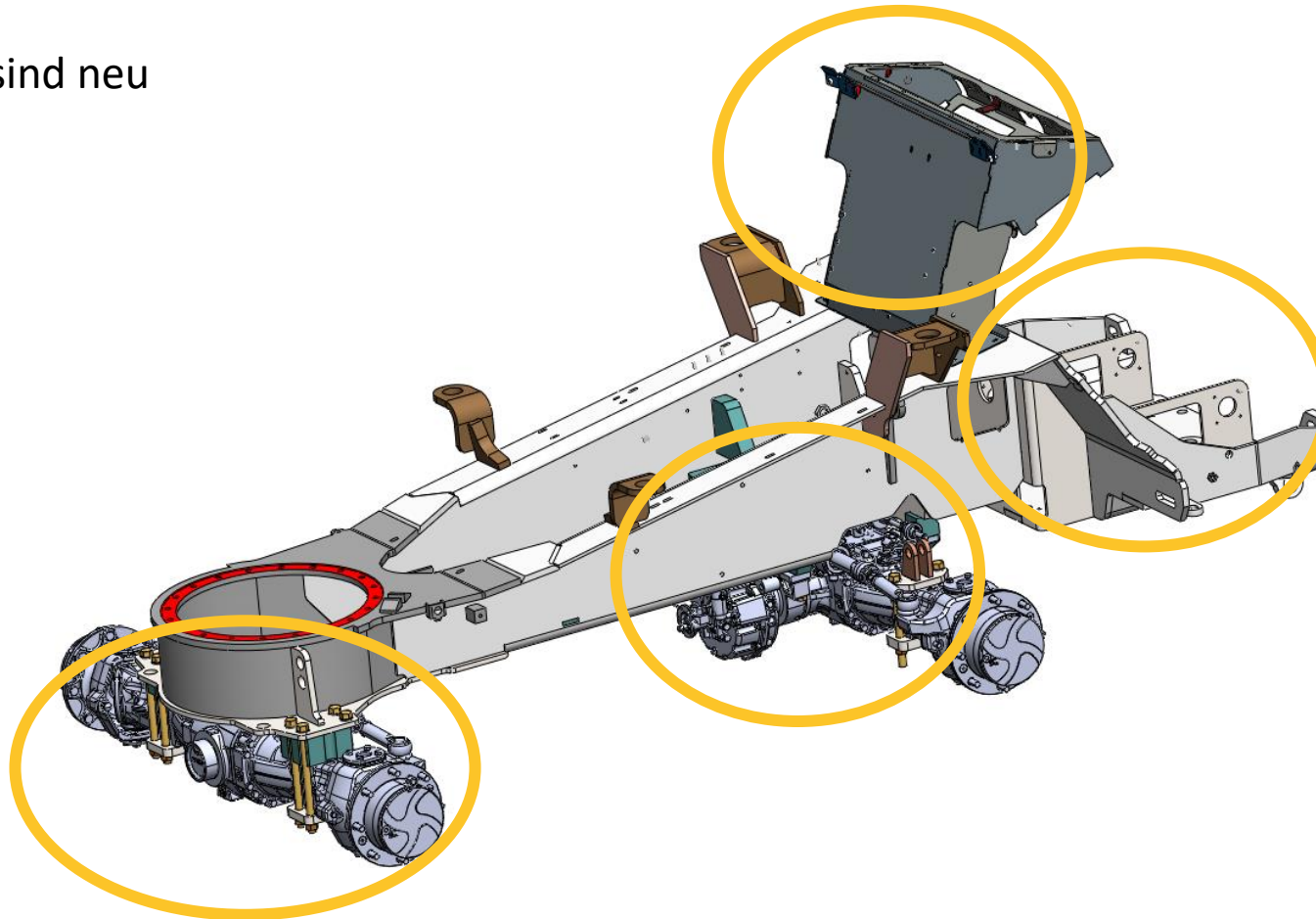



Gleichteile

Komponenten und größtenteils Schläuche werden übernommen

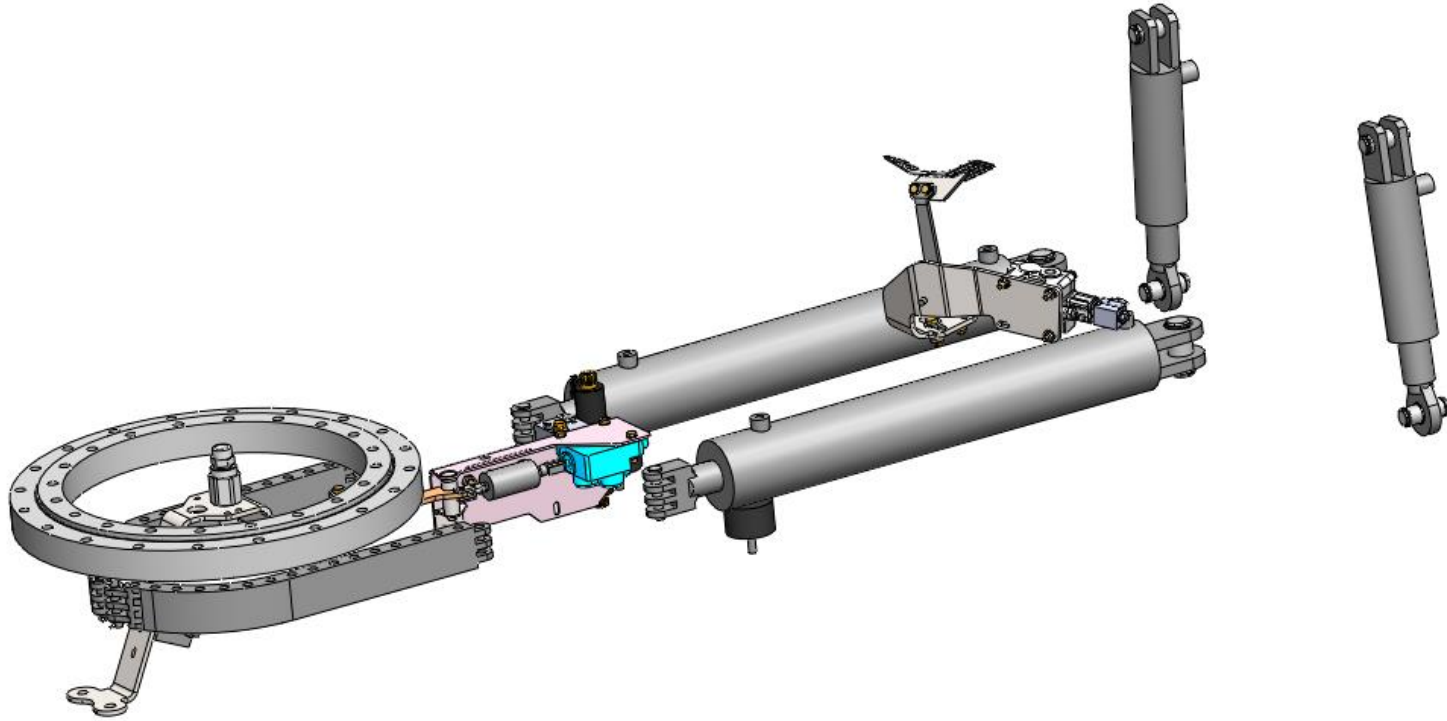



Gleichteile

Öltank und Hydraulikteile





Gleichteile

Schaufelarm komplett mit Drehstuhl identisch





Gleichteile

Komplette Kabine
Neue Bremsanlage

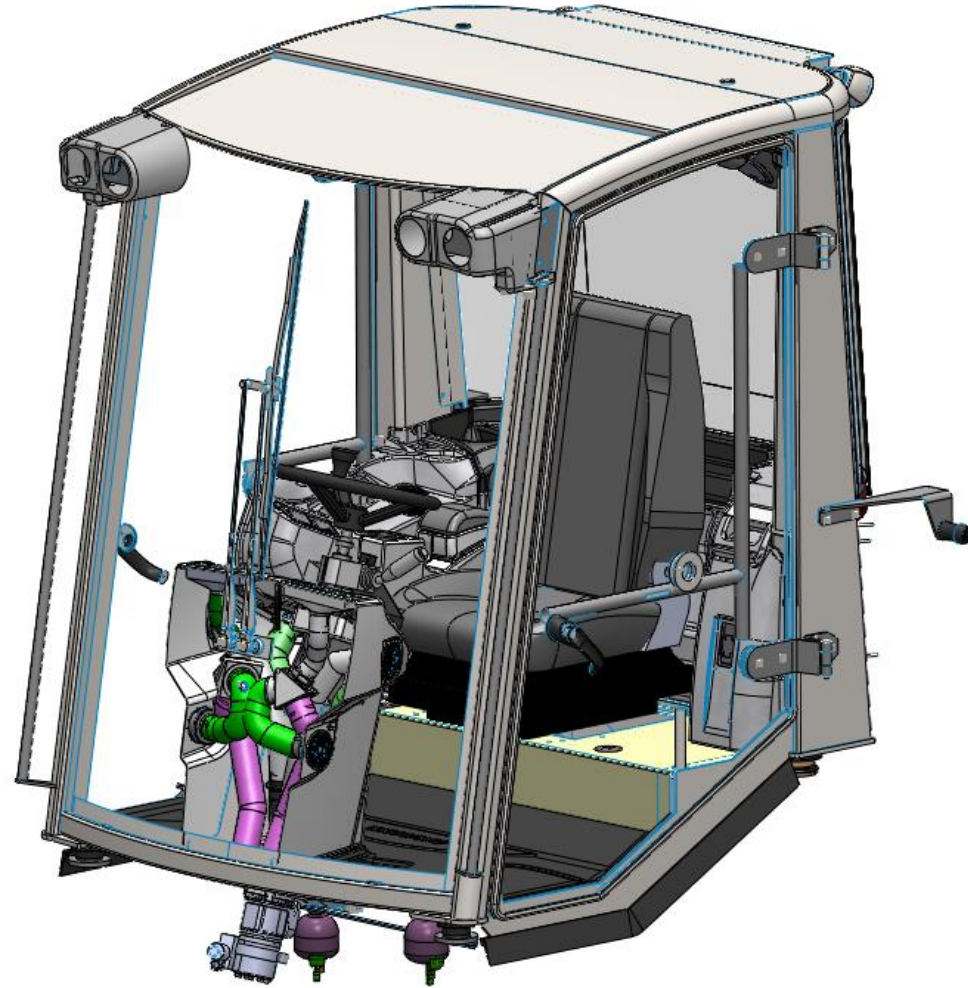



Gleichteile

Auspuffrohr fehlt





ES1000



ON-BOARD
CHARGER

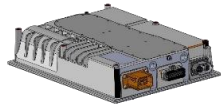

BATTERIE
HIGH
VOLTAGE

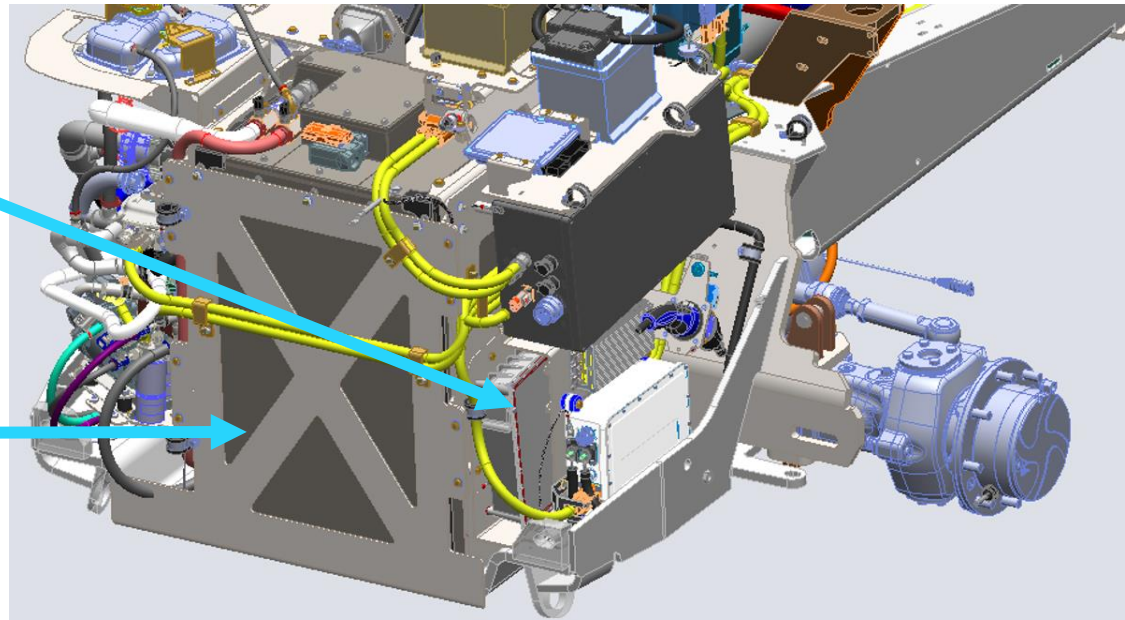



ES1000

380V, blue harnesses



ON-BOARD CHARGER

BATTERIES HIGH VOLTAGE

POWER DISTRIB. UNIT (PDU)

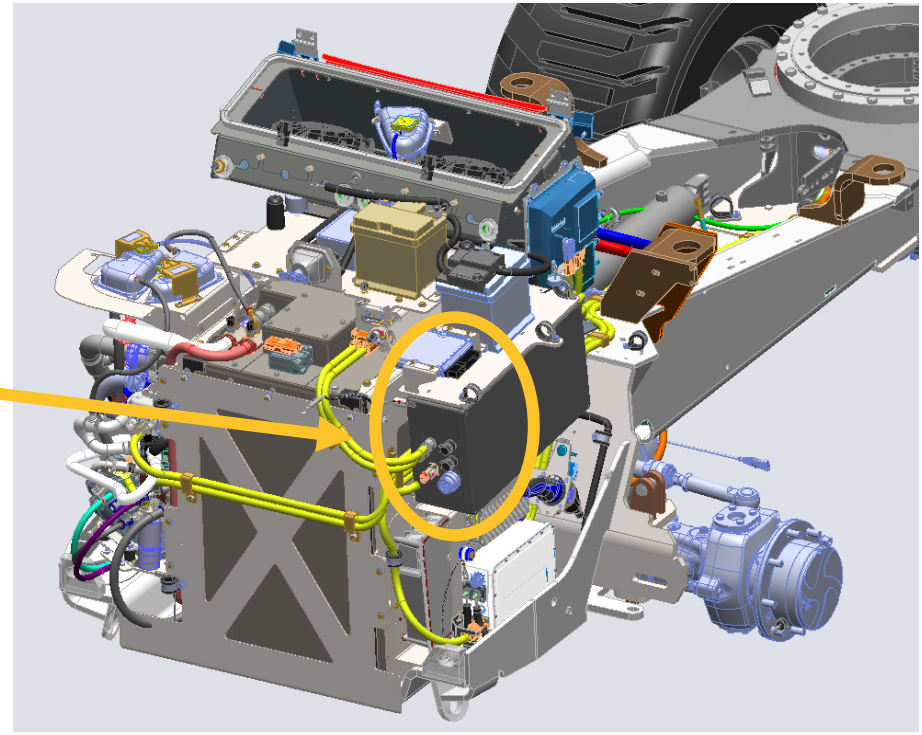



ES1000

380V, blue harnesses

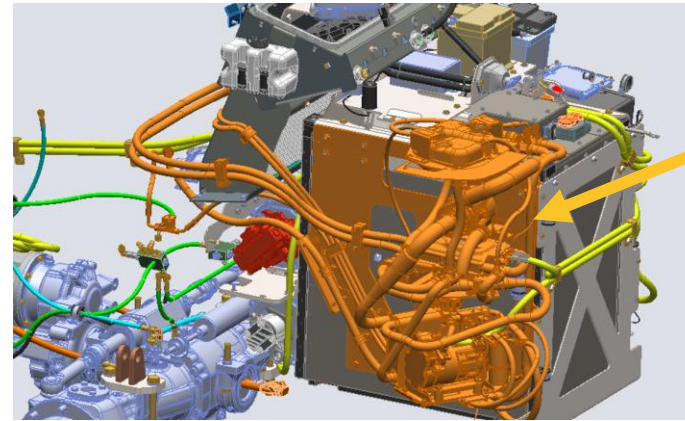
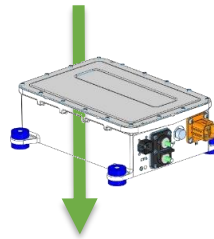
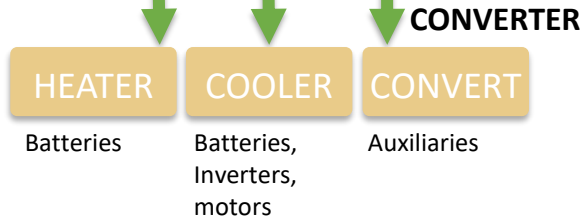
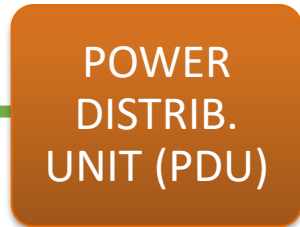
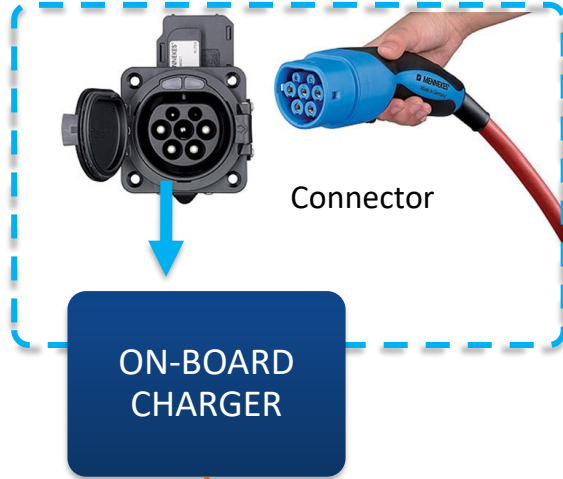

COOLING

HEATING

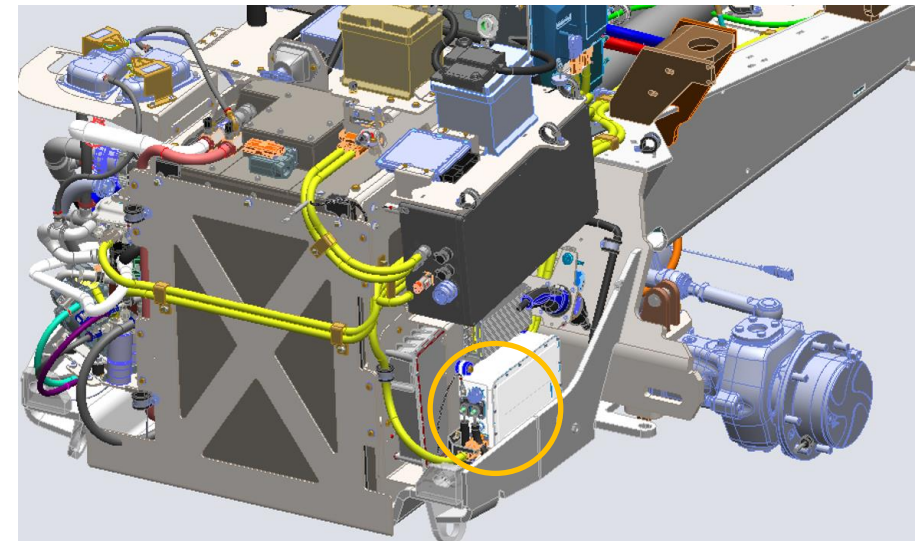

DC>DC Converter, 4kW



ES1000

380V, blue harnesses



Connector

ON-BOARD CHARGER

700V, orange harnesses

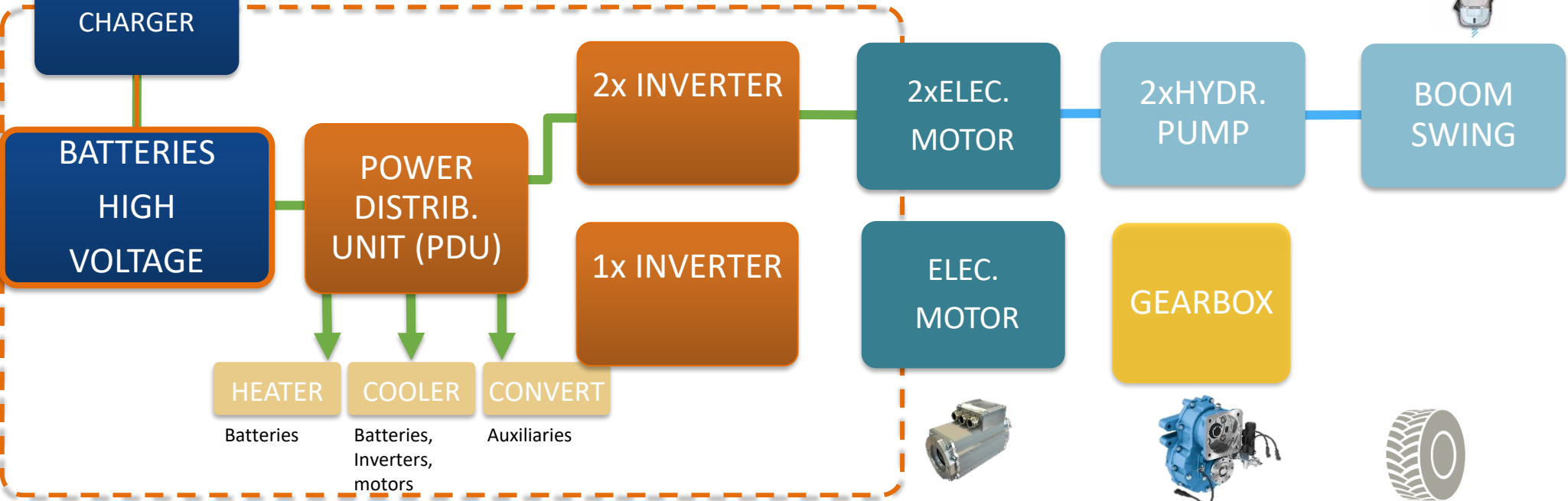

x 2!

BATTERIES
HIGH
VOLTAGE

POWER
DISTRIB.
UNIT (PDU)

HEATER

Batteries

COOLER

Batteries,
Inverters,
motors

CONVERT

Auxiliaries

2x INVERTER

1x INVERTER

2xELEC.
MOTOR

ELEC.
MOTOR

2xHYDR.
PUMP

GEARBOX

BOOM
SWING



POWER - COMPONENTS

IMPLEMENTS:

- 2 electric inverter, *SEVCON*
- 2 electric motor, *PARKER*
- 2 pump, *BUCHER*, fix displacement,



TRANSMISSION:

- 1 electric inverter, *SEVCON*
- 1 electric motor, *PARKER*, 64 kw | 171Nm (126 lbf.ft)
- 1 mechanical gearbox, *DANA* Shift-on-Fly, 2 auto. gears





POWER - COMPONENTS

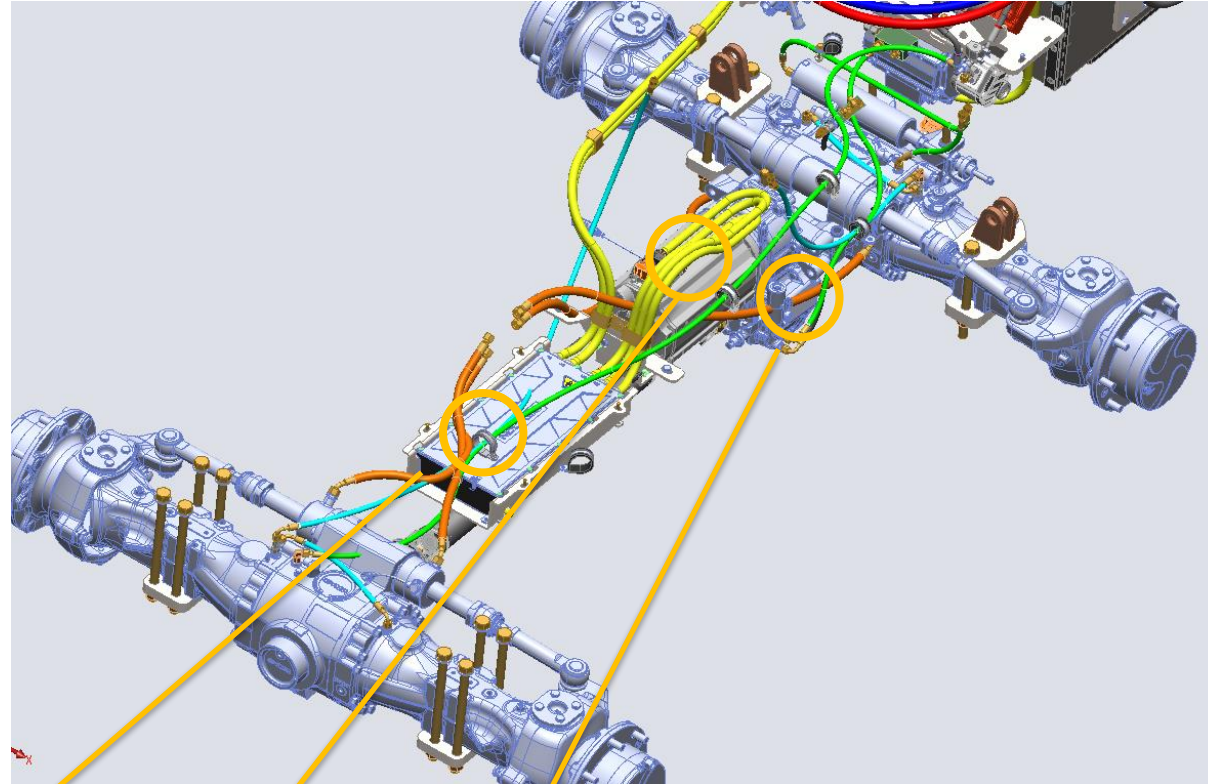

TRANSMISSION:

- 1 electric inverter, *SEVCON*
- 1 electric motor, *PARKER*, 64 kw | 171Nm (126 lbf.ft)
- 1 mechanical gearbox, *DANA* Shift-on-Fly, 2 auto. gears



POWER - COMPONENTS

IMPLEMENTS:

- 2 electric inverter, *SEVCON*
- 2 electric motor, *PARKER*
- 2 pump, fix displacement,

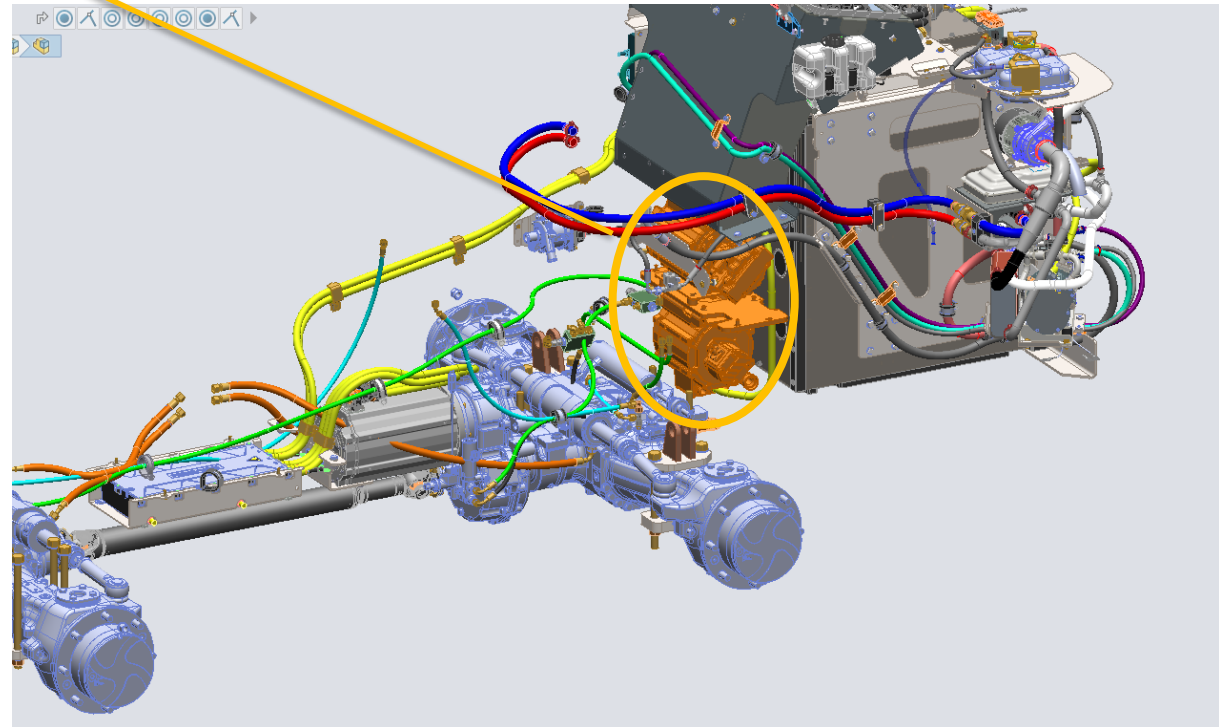



ES1000

Nächste Schritte

- Optimierung Software
- Erprobung auf der Baustelle
- Fertigung von Kundenmaschinen





ES1000



Vielen Dank für Ihre Aufmerksamkeit